

EN-US - english US



## Instructions for installation and operation

Condensate drain

**BEKOMAT® 31U built-in F** (BM31UBIF)

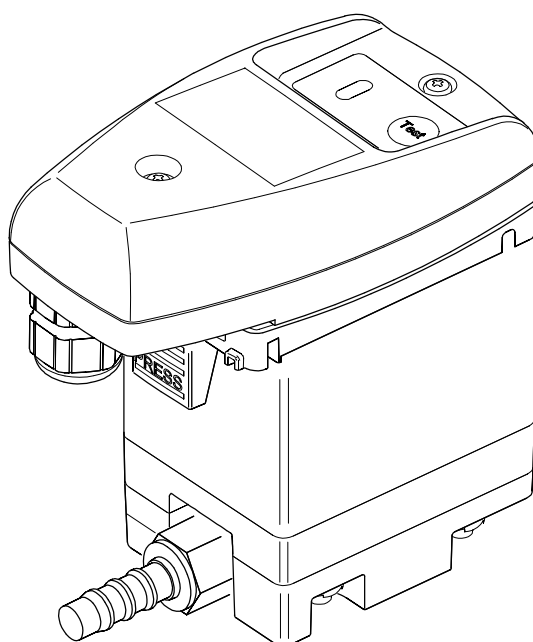

---

Dear customer,

Thank you for deciding in favor of the BEKOMAT® 31U built-in F condensate drain. Please read the installation and operating instructions carefully before mounting and starting up the BEKOMAT® 31U built-in F, and follow our directions. Perfect functioning of the BEKOMAT® 31U built-in F, and thus reliable condensate discharge, can only be guaranteed when the provisions and notes stipulated here are strictly adhered to.

---

1	Pictograms and symbols .....	4
2	Safety instructions .....	4
3	Proper use .....	6
4	Exclusion from the scope of application .....	6
5	Technical data .....	7
6	Electrical data .....	7
7	Dimension drawing .....	8
8	Function .....	9
9	Installation .....	11
10	Electrical installation .....	14
11	Control and maintenance .....	17
12	Troubleshooting and fault elimination .....	21
13	Elements and components .....	22
14	Recommended spare parts .....	23
15	Accessories .....	23
16	Declaration of conformity .....	24

### 1 Pictograms and symbols



Observe the installation and operating instructions



Observe the installation and operating instructions  
(on the type plate)



General danger symbol (danger, warning, caution)



General danger symbol (danger, warning, caution) for supply voltage and supply voltage-carrying plants components

### 2 Safety instructions



**Please check whether or not these instructions correspond to the device type.**

Adhere to all advice given in these operating instructions. They include essential information which must be observed during the installation, operation and maintenance. Therefore it is imperative for the service technician and the responsible operator / technical staff to read these operating instructions prior to installation, start-up and maintenance.

The operating instructions must be accessible at any time at the place of application of the BEKOMAT® 31U.

In addition to these operating instructions, local or national regulations must be complied with, if necessary.

Make sure that the BEKOMAT® 31U is operated only within the permissible limit values indicated on the type plate. Any deviation involves a risk for persons and materials, and may result in malfunction and service failures.

If you have any queries regarding these installation- and operating instructions, please contact BEKO TECHNOLOGIES CORP.



**Danger!**

**Compressed air!**

**Risk of serious injury or death through contact with quickly or suddenly escaping compressed air or through bursting plant components or plant components which are not secured.**

#### Measures:

- Do not exceed the maximum operating pressure (see type plate).
- **Only carry out service measures when the system is pressure less.**
- Use pressure-resistant installation material only.
- The feed pipe must be tubed firmly. Discharge pipe: short, fixed pressure hose onto pressure-resistant pipe.
- Make sure that persons or objects cannot be hit by condensate or escaping compressed air.



### **Danger!**

#### **Supply voltage!**

**There is the risk of an electric shock involving injury or death when coming into contact with non-insulated components carrying supply voltage.**

#### **Measures:**

- During electric installations, all regulations in force need to be adhered to (e.g. VDE 0100 / IEC 60364).
- **When the control unit is open, service and installation works must only be undertaken when the system is deactivated.**
- **The removed control unit has no IP degree of protection.**
- All types of electrical works must be carried out by authorized and qualified personnel only.

#### **Further safety instructions:**

- For installation and operation, the national regulations and safety codes in force must also be adhered to.
- Do not use the BEKOMAT® 31U in hazardous areas.
- Regarding the inlet screw joints, excessive tightening forces must be avoided. This applies in particular to conical screw joints.
- The BEKOMAT® 31U will only function when voltage is applied.
- Do not use the test button for permanent drainage.
- Use genuine spare parts only. This is imperative to ensure perfect functioning.

#### **Additional advice:**

- The removed control unit has **no IP degree of protection**.
- During installation, use spanner flat at the feed pipe (wrench size SW27) as a back rest.
- The service unit must not be dismantled.



### **Caution!**

#### **Malfunction during operation!**

**Through incorrect installation and poor maintenance, malfunction may occur at the BEKOMAT.**

**Condensate which is not discharged may cause damage to plants and in production processes.**

#### **Measures:**

- Condensate drainage which is reliable in performance directly optimizes the compressed-air quality.
- To prevent damage and breakdowns, it is imperative to observe the following:
  - Exact compliance with the specifications of use and with the performance parameters of the BEKOMAT, in connection with the case of application (see "Proper use" section)
  - Exact compliance with the installation- and operation instructions in this manual
  - Regular maintenance and control of the BEKOMAT in accordance with the instructions in this operating manual

### 3 Proper use

- The BEKOMAT® 31U built-in F is an electronically level-controlled condensate drain for compressed-air plants.
- The device is employed within the permissible performance parameters (see "Technical data").
- The BEKOMAT® 31U built-in F is able to drain condensate under operating pressure from the plant components virtually without compressed-air loss.
- For its function, the BEKOMAT® 31U built-in F requires an supply voltage and an operating pressure (see "Technical data").
- As far as the employment in plants with increased demands on compressed air is concerned (food industry, medical technology, laboratory equipment, special processes etc.), the operator must decide on measures for the monitoring of the compressed-air quality. These have an effect on the safety of the subsequent processes and may prevent damage to persons and plants.
- It is the task of the operator to ensure that the indicated conditions are met during the entire operating time.

### 4 Exclusion from the scope of application

- The BEKOMAT® 31U built-in F as a condensate drain **alone cannot** guarantee a defined compressed-air quality, for this purpose, other additional technical devices are required.
- BEKOMAT® 31U built-in F is **not** suitable for use in plants carrying vacuum or atmospheric ambient pressure or in ex-areas.
- The BEKOMAT® 31U built-in F must not be exposed to permanent direct solar or thermal radiation.
- The BEKOMAT® 31U built-in F must not be installed and operated in areas with an aggressive atmosphere.
- The BEKOMAT® 31U built-in F is not heatable and, therefore, not suitable for the use in areas where frost is likely to occur.
- The BEKOMAT® 31U built-in F is not suitable for CO<sub>2</sub> plants.

## 5 Technical data

	
min./max. operating pressure (see type plate)	0,8...16 bar (12...230 psi) or 1,2...16 bar (17...230 psi)
min./max. temperature (see type plate)	+1...+60 °C (+34...+140 °F) or +1...+70 °C (+34...+158 °F)
Condensate inflow	NPT ½ (G ½) internal max. screw-in depth 13,5 mm (½")
Condensate outflow	G ¼ Ø 8 ... 10 mm hose connector
Condensate	oil-contaminated + oil-free
Housing	aluminium + plastic, glass fibre-reinforced
Weight (empty)	0,6 kg (1.3 lbs)

This product has been tested to the requirements of CAN/CSA-C22.2 No. 61010-1-12, third edition, including a later version of the same standard incorporating the same level of testing requirements.

## 6 Electrical data

Supply voltage (see type plate)	95...240 VAC ±10% (50...60 Hz) / 100...125 VDC ±10% or 24...48 VAC ±10% (50...60 Hz) / 18...72 VDC ±10%
Power consumption	P = 0,6 ... 3 VA (W)
Recommended cable-jacket diameter	Ø 5,0...10 mm (0,20"...0,39")
Recommended wire cross-section Spring-loaded terminal	0,75...1,5 mm <sup>2</sup> (AWG 16...20)
Recommended wire cross-section Screw terminal	0,75...2,5 mm <sup>2</sup> (AWG 14...20)
Recommended stripping of cable jacket	~ 50 mm (~ 1.97")
Recommended length of the wire end tube Spring-loaded terminal	~ 8 mm (~ 0.31 inch)
Recommended length of the wire end tube Screw terminal	~ 6 mm (~ 0.24 inch)
Protection class	IP 67
Overvoltage category (IEC 61010-1)	II

VAC = V alternating current  
VDC = V direct current

7 Dimension drawing

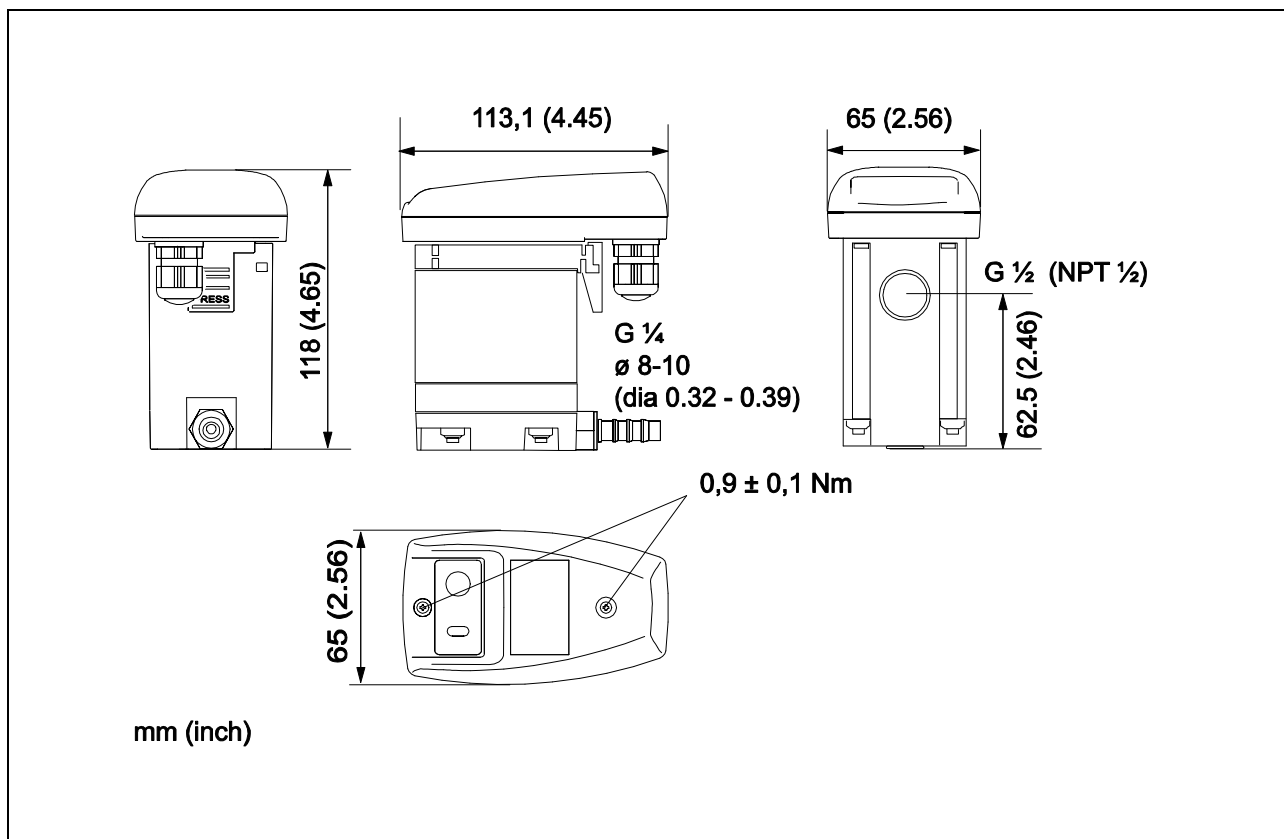



8 Function

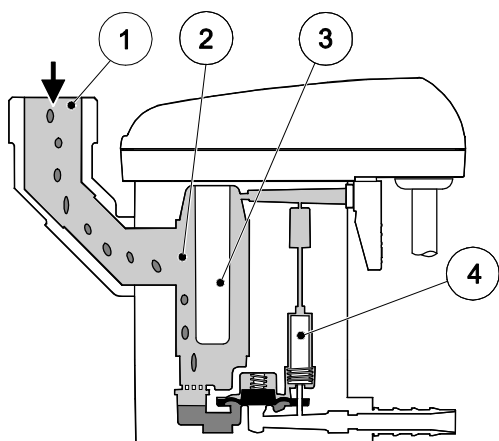

Via the inlet line (1) the condensate flows into the BEKOMAT® 31U built-in F and accumulates in the housing (2).

A capacitive functioning sensor (3) continuously registers the filling level and relays a signal to the electronic control as soon as the container is filled.

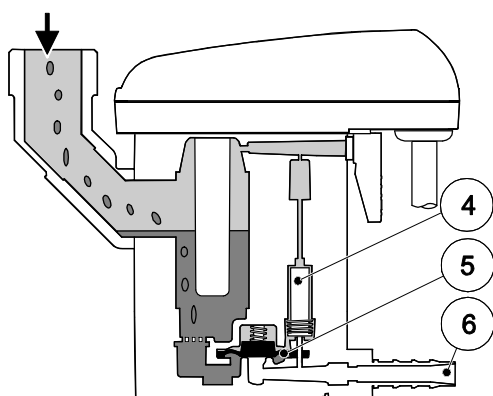

The pilot valve (4) is activated and the membrane (5) opens the outlet line to discharge the condensate (6).

When the BEKOMAT® 31U built-in F is empty, the outlet line is reclosed tightly in time before unnecessary compressed-air losses occur.

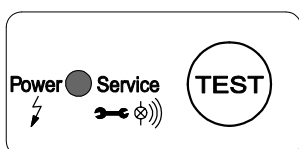

When applying supply voltage, the BEKOMAT® 31U carries out a **self-test**.

The LED is lit orange for 1 second; subsequently, the device changes over to the "ready-to-operate" state and the LED is lit green.

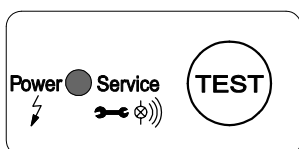

**Ready to operate, voltage is applied.**

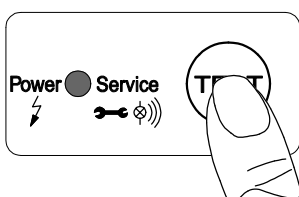

Test of the valve function (manual drainage):  
Press and hold the push-button for approx. 2 s.

**Do not use for permanent drainage.**

The BEKOMAT® 31U built-in F releases a maintenance message for a service that is to be carried out.

Depending on the operating mode, a visual maintenance message (service) is activated which signalizes the replacement of the service unit.

The maintenance message is indicated by the flashing supply voltage-LED "Power".

The maintenance message is released after  $2 \times 8.760$  h or one million switching cycles.

The maintenance signal is released when one of these two values is reached.

In the event of a power outage or when the energy supply is deactivated, the status of the timer will be maintained.

The activities to be carried out regarding maintenance are described in the chapter entitled "Check and maintenance".

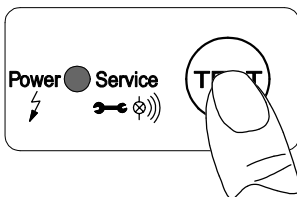
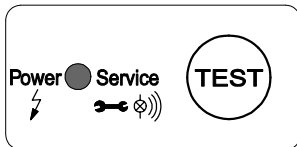

Prior to the replacement of the service unit, a reset needs to be carried out. The control unit is released by actuating the arresting hook. When removed, the TEST button must be pressed and held for at least five seconds.

## 9 Installation



### **Danger!**

#### **Compressed air!**

**Risk of serious injury or death through contact with quickly or suddenly escaping compressed air or through bursting plant components or plant components which are not secured.**

#### **Measures:**

- Do not exceed the maximum operating pressure (see type plate).
- **Only carry out service measures when the system is pressure less.**
- Use pressure-resistant installation material only.
- The feed pipe must be tubed firmly. Discharge pipe: short, fixed pressure hose onto pressure-resistant pipe.
- Make sure that persons or objects cannot be hit by condensate or escaping compressed air.



### **Caution!**

#### **Malfunction during operation!**

**Through incorrect installation and poor maintenance, malfunction may occur at the BEKOMAT.**

**Condensate which is not discharged may cause damage to plants and in production processes.**

#### **Measures:**

- Condensate drainage which is reliable in performance directly optimizes the compressed-air quality.
- To prevent damage and breakdowns, it is imperative to observe the following:
  - Exact compliance with the specifications of use and with the performance parameters of the BEKOMAT, in connection with the case of application (see "Proper use" section)
  - Exact compliance with the installation- and operation instructions in this manual
  - Regular maintenance and control of the BEKOMAT in accordance with the instructions in this operating manual

## Installation



### Note

It is imperative to observe all hazard statements and warnings listed here.

Please also observe all regulations and notes regarding industrial safety and fire prevention at the place of installation.

As a matter of principle, only use suitable and appropriate tools and materials in a proper condition.

Do not use aggressive cleaners and improper devices such as high-pressure cleaners.







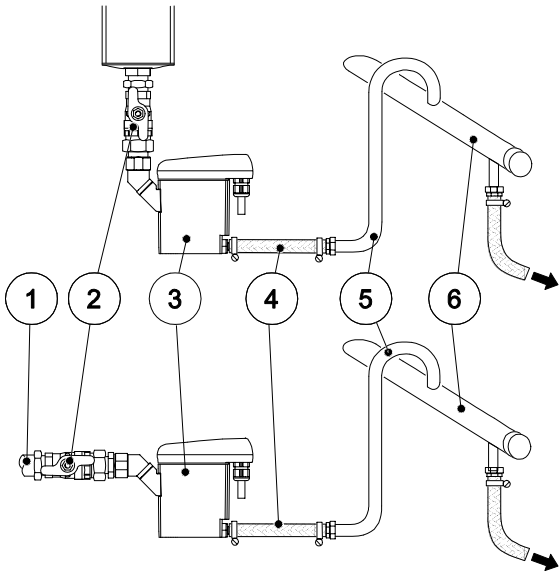

Please note that condensates may contain aggressive or harmful components. Therefore, skin contact should be avoided.

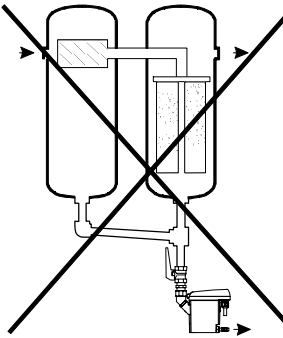
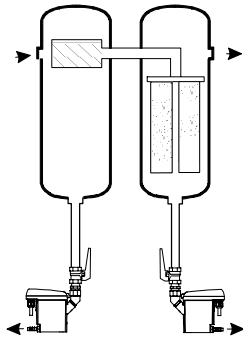
Condensate is subject to mandatory waste disposal. As such, it must be collected in suitable containers, and disposed of or processed properly.

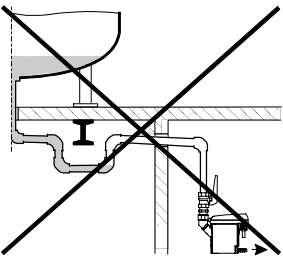
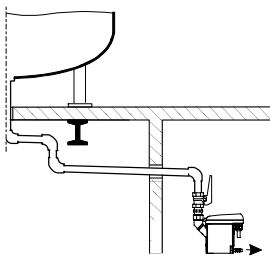
### Installation instructions:

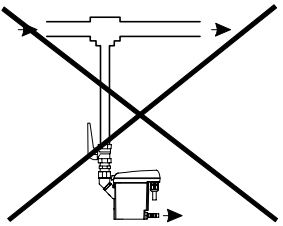
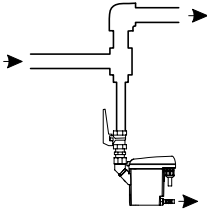

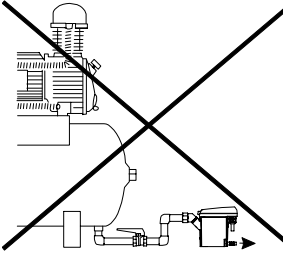
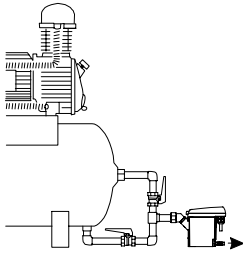
- Only the displayed installation position of the BEKOMAT (3) is permissible. Never install in a horizontal or any other tilted position.
- Feed pipe (1) and ball valve (2) at least G $\frac{1}{2}$ .
- No filter or screen in the inlet line.
- Slope in the inlet line >1%.
- Use ball valves (2) only.
- Operating pressure: min. 0,8/1,2 bar (12/17 psig), max. 16 bar (230 psig). See type plate.
- Short pressure hose (4) fixed on a pressure-resistant pipe.
- The required minimum pressure increases by 0,1 bar (1,4 psi) per metre gradient in the discharge pipe (5).
- Discharge pipe (5) rising by max. 5 m (16,4ft).
- Install manifold (6)  $\frac{1}{2}$ " with a slope of 1%.
- Introduce the discharge pipe (5) from the top into the manifold (6).
- Prior to the start-up, always carry out a leak test and verify the correct engagement of the control unit.

wrong	correct	
		<p> <b>Pressure differences!</b></p> <p>Each condensate accumulation point must be drained separately.</p>
		<p> <b>Continuous slope!</b></p> <p>Avoid a water pocket when installing the feed pipe</p>
		<p> <b>Deflector area!</b></p> <p>If drainage is to be carried out directly from the pipe, deflection of the air flow will be useful.</p>
		<p> <b>Ventilation!</b></p> <p>If the slope in the inlet line is not sufficient or if any other inflow problems occur, a venting line needs to be installed.</p>

### 10 Electrical installation



**Danger!**

**Supply voltage!**

There is the risk of an electric shock involving injury or death when coming into contact with non-insulated components carrying supply voltage.

#### Measures:

- During electric installations, all regulations in force need to be adhered to (e.g. VDE 0100 / IEC 60364).
- **When the control unit is open, service and installation works must only be undertaken when the system is deactivated.**
- **The removed control unit has no IP degree of protection.**
- All types of electrical works must be carried out by authorized and qualified personnel only.

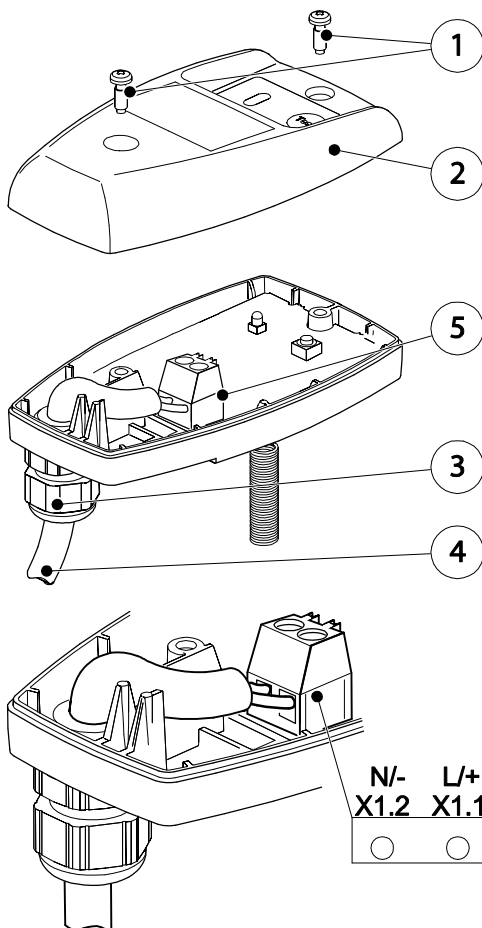

#### Note:

1. Read the permissible supply voltage on the type plate and make sure this voltage is observed.
2. For the supply voltage, a reliably accessible separator must be provided close-by (e.g. power plug or switch), which separates all current-carrying conductors.
3. At a low-voltage supply (< 50 VAC / < 75 VDC), only use a protective extra-low-voltage.
4. Carry out installation in accordance with VDE 0100 / IEC 60364.
5. Observe the terminal assignment.
6. Do not install when the device is energized.
7. Unscrew the screws (1) and remove the upper part of the cover (2).
8. Unscrew the threaded cable connection (3), remove the plug (if there is one), and lead the cable (4) for the power supply through.
9. Connect the cable (4) with terminals X1 (1.1, 1.2) (5).
10. Install the cables as shown (see also terminal assignment in the following text).
11. Tighten the threaded cable connection (3) with a slightly sealing effect.
12. Put on the upper part of the cover (2) and tighten the screws (1) fingertight.

**Terminal assignment supply voltage (operating voltage)**

X 1	
L/+	N/-
phase	neutral
1.1	1.2

Power supply

- X 1.1 L/+
- X 1.2 N/-

L = Outer conductor  
N = Neutral conductor

**Terminal assignment low voltage (operating voltage)**

X 1	
L/+	N/-
power	power
1.1	1.2

Power supply

- X 1.1 L/+
- X 1.2 N/-



## Electrical installation



### Note:

At a low voltage supply (< 50 VAC / < 75 VDC), only use a protective extra-low-voltage.  
Tighten the threaded cable connection with a slightly sealing effect.

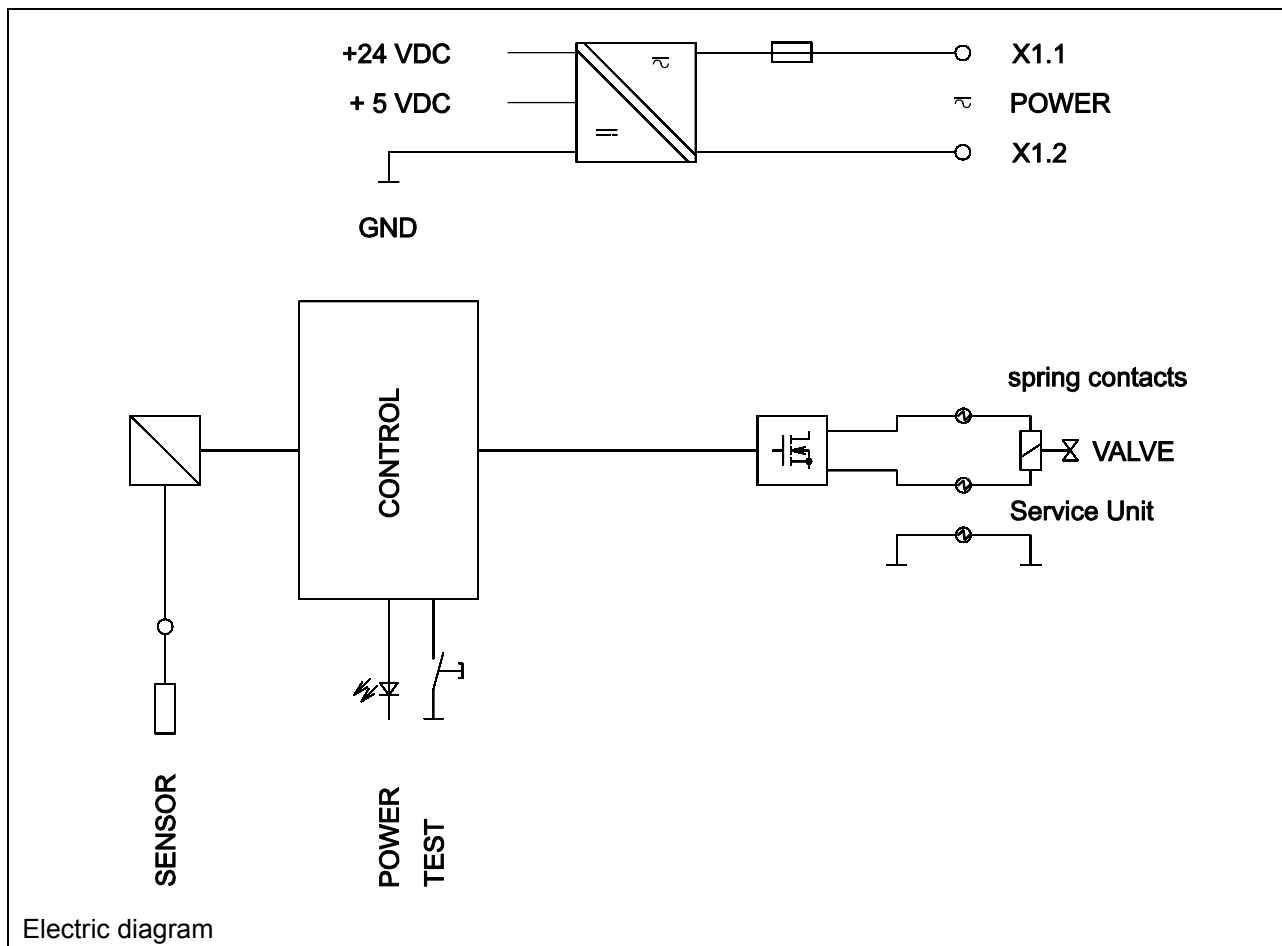



## 11 Control and maintenance



### Danger!

#### Compressed air!

**Risk of serious injury or death through contact with quickly or suddenly escaping compressed air or through bursting plant components or plant components which are not secured.**

#### Measures:

- Do not exceed the maximum operating pressure (see type plate).
- **Only carry out service measures when the system is pressure less.**
- Use pressure-resistant installation material only.
- The feed pipe must be tubed firmly. Discharge pipe: short, fixed pressure hose onto pressure-resistant pipe.
- Make sure that persons or objects cannot be hit by condensate or escaping compressed air.



### Danger!

#### Supply voltage!

**There is the risk of an electric shock involving injury or death when coming into contact with non-insulated components carrying supply voltage.**

#### Measures:

- During electric installations, all regulations in force need to be adhered to (e.g. VDE 0100 / IEC 60364).
- **When the control unit is open, service and installation works must only be undertaken when the system is deactivated.**
- **The removed control unit has no IP degree of protection.**
- All types of electrical works must be carried out by authorized and qualified personnel only.



### Caution!

#### Malfunction during operation!

**Through incorrect installation and poor maintenance, malfunction may occur at the BEKOMAT.**

**Condensate which is not discharged may cause damage to plants and in production processes.**

#### Measures:

- Condensate drainage which is reliable in performance directly optimizes the compressed-air quality.
- To prevent damage and breakdowns, it is imperative to observe the following:
  - Exact compliance with the specifications of use and with the performance parameters of the BEKOMAT, in connection with the case of application (see "Proper use" section)
  - Exact compliance with the installation- and operation instructions in this manual
  - Regular maintenance and control of the BEKOMAT in accordance with the instructions in this operating manual



### Note

It is imperative to observe all hazard statements and warnings listed here.

Please also observe all regulations and notes regarding industrial safety and fire prevention at the place of installation.

As a matter of principle, only use suitable and appropriate tools and materials in a proper condition.

Do not use aggressive cleaners and improper devices such as high-pressure cleaners.

Please note that condensates may contain aggressive or harmful components. Therefore, skin contact should be avoided.

Condensate is subject to mandatory waste disposal. As such, it must be collected in suitable containers, and disposed of or processed properly.

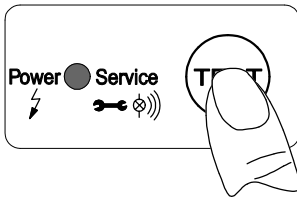
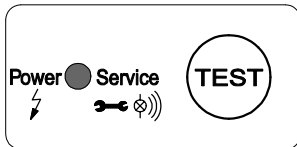

### Maintenance recommendation:

After 2 x 8,760 operating hours or one million switching cycles, a maintenance message is released. The green power LED flashes. Afterwards, or at the latest after two years (2 x 8,760 operating hours), the service unit (5) needs to be replaced.

1. Prior to the replacement of the service unit, a reset needs to be carried out. The control unit is released by actuating the arresting hook. When removed, the TEST button below the LED must be pressed and held for at least five seconds.

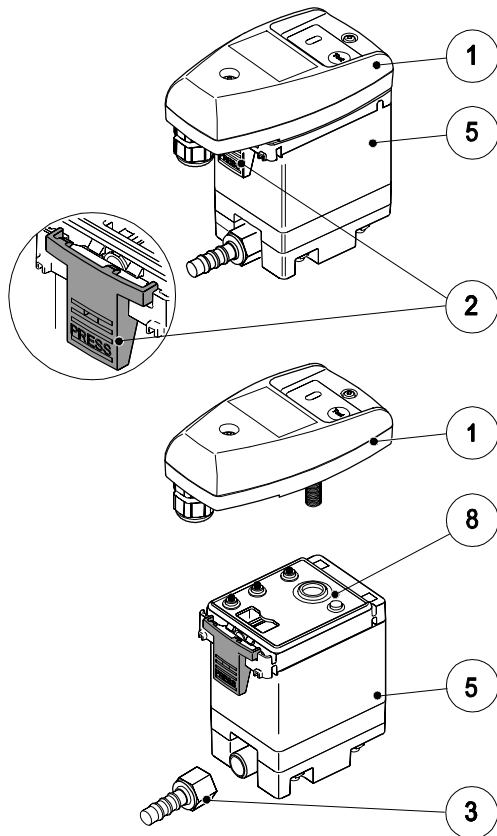

2. Remove the control unit (1) by pressing the arresting hook (2).
3. Unfasten the BEKOMAT® 31U from the outlet (3).
4. Detach the service unit (5) from the tubing at the inlet by removing the union nut.

5. Check whether or not the new service unit (5) goes with the control unit (1) (model designation and color of the arresting hook (2)).

6. Installation of the new service unit (5) in reverse order.

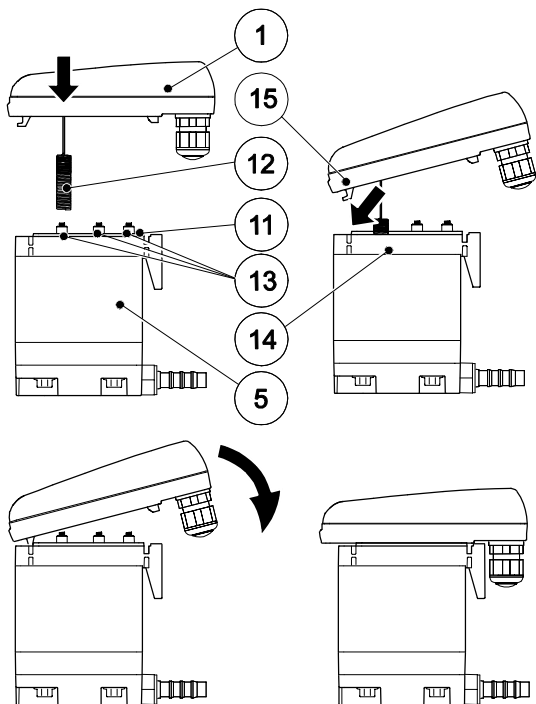

### Installation of the control unit on the service unit:

1. Check whether or not the service unit (5) goes with the control unit (1) (model designation and color of the arresting hook).
2. Check whether or not the sealing mat (11) and the contact springs (13) are clean, dry, and free from impurities.
3. Introduce the sensor (12) into the sensor tube plate (14).
4. Hang the hook (15) of the control unit (1) in the sensor tube plate (14).
5. Press the control unit (1) against the service unit (5) and snap into place

### Start-up subsequent to maintenance measures:

Always carry out prior to the start-up:

- Leak test of the screwed connector
- Check of the electrical connections
- Check of the correct engagement of the control unit

12 Troubleshooting and fault elimination

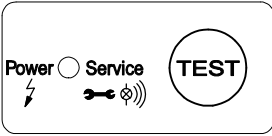
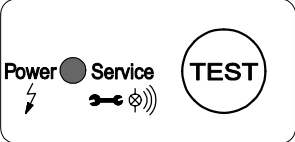
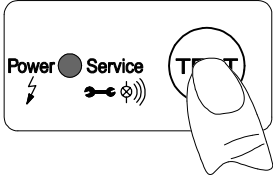
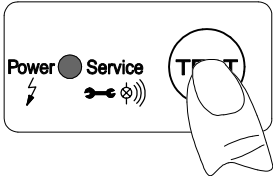
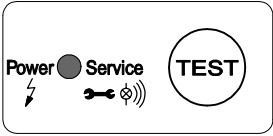
Symptoms	Possible reasons	Measures
 <p><b>LED does not light up</b></p>	<p>Supply voltage incorrect Circuit board defective</p>	<p>Check voltage on the type plate Check the connections and the supply voltage Check the circuit boards for possible damage</p>
 <p><b>LED lights continuously orange</b></p>	<p>Failure during the start of the programme Circuit board defective</p>	<p>Separate the device from the supply voltage and reactivate after &gt; 5 s Check the circuit boards for possible damage</p>
 <p><b>Test button pressed, but no condensate discharge</b></p>	<p>Feed pipe and/or discharge pipe blocked or obstructed Wear and tear Circuit board defective Service unit defective Minimum pressure not reached Maximum pressure exceeded</p>	<p>Check feed and discharge pipe Check whether or not the valve opens audibly (press the test button several times for &gt; 2 seconds) Check the circuit board for possible damage Check the operating pressure</p>
 <p><b>Condensate discharge only when the test button is pressed</b></p>	<p>Feed pipe without sufficient slope Cross section not large enough Condensate accumulation too high (surge) Service unit extremely dirty</p>	<p>Install feed pipe with a slope Replace the service unit</p>
 <p><b>Device blows off continuously</b></p>	<p>Service unit defective or dirty</p>	<p>Replace the service unit</p>

### 13 Elements and components

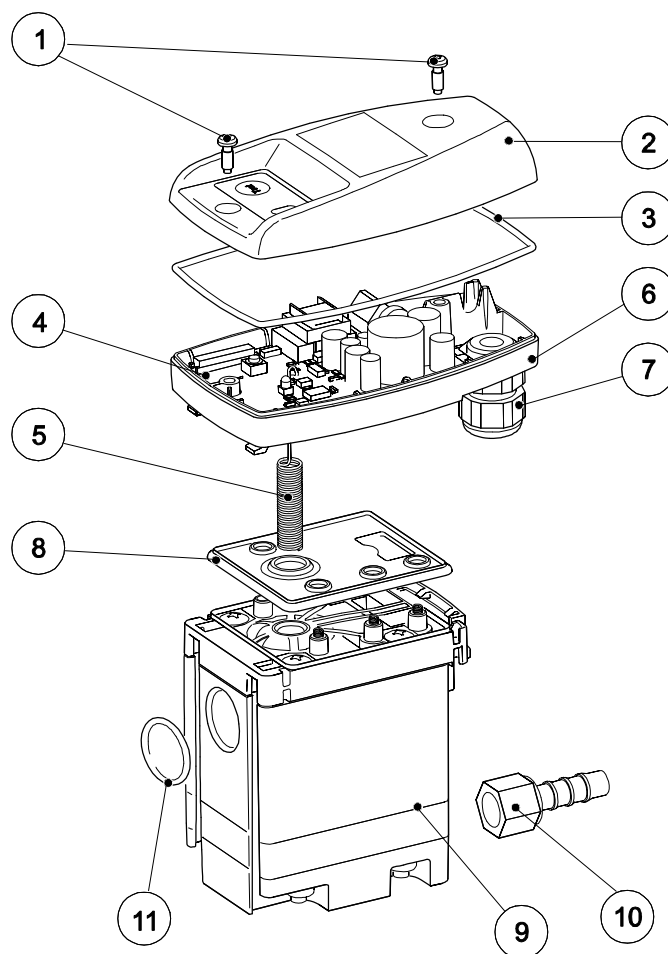

- 1 Screw 3.5 x 10
- 2 Upper part of the cover
- 3 Moulded gasket
- 4 Circuit board
- 5 Sensor
- 6 Lower part of the cover

- 7 Cable bushing
- 8 Sealing mat
- 9 Service unit
- 10 Hose connector
- 11 O-ring 20 x 2

## 14 Recommended spare parts

Available sets of spare parts	Contents	Order number
Service unit F	8, 9, 11*	4023608
Gasket kit	3, 8, 11*	4024386
Design shell*	16*	4010164
Connection adapter G*	11*, 12*, 13*, 14*, 15*	4010155
Connection adapter NPT*		4012610

\* Not for BEKOMAT 31U built-in F

## 15 Accessories

Available accessory sets	Contents	Order number
Outlet set With a hose and installation material	Tubing piece 10x3x800 Grommet 9-G½ Ms Hose clamp 12-22/9 A2	2000045

### 16 Declaration of conformity

BEKO TECHNOLOGIES GMBH  
41468 Neuss, GERMANY  
Tel: +49 2131 988-0  
www.beko-technologies.com



## EG-Konformitätserklärung

Wir erklären hiermit, dass die nachfolgend bezeichneten Produkte den Anforderungen der einschlägigen Richtlinien und technischen Normen entsprechen. Diese Erklärung bezieht sich nur auf die Produkte in dem Zustand, in dem sie von uns in Verkehr gebracht wurden. Nicht vom Hersteller angebrachte Teile und/oder nachträglich vorgenommene Eingriffe bleiben unberücksichtigt.

Produktbezeichnung:	Kondensatableiter
Modelle:	BEKOMAT 31U, 32U, 32UV, 33U, 33UV
Spannungsvarianten:	95...240 VAC $\pm 10\%$ (50...60 Hz) / 100...125 VDC $\pm 10\%$ oder 24...48 VAC $\pm 10\%$ (50...60 Hz) / 18...72 VDC $\pm 10\%$
Betriebsdruckbereich:	0,8...16 bar (12...230 psi) oder 1,2...16 bar (17...230psi)
Produktbeschreibung und Funktion:	Kondensatableiter zur elektronisch niveaugeregelten Ableitung von Kondensat im Druckluftnetz.

#### Niederspannungs-Richtlinie 2006/95/EG

Angewandte harmonisierte Normen: EN 61010-1:2010  
Anbringungsjahr der CE-Kennzeichnung: 13

Die Geräte mit einer Betriebsspannung von 24...48 VAC und 18...72 VDC fallen nicht in den Anwendungsbereich der Niederspannungs-Richtlinie.

#### EMV-Richtlinie 2004/108/EG

Angewandte harmonisierte Normen: EN 61326-1:2006  
EN 55011:2009 + A1: 2010, Gruppe 1, Klasse B

#### RoHS Richtlinie 2011/65/EU

Die Vorschriften der Richtlinie 2011/65/EU zur Beschränkung der Verwendung bestimmter gefährlicher Stoffe in Elektro- und Elektronikgeräten werden erfüllt.

Neuss, 21.08.2013

BEKO TECHNOLOGIES GMBH

A handwritten signature in black ink, appearing to read "Christian Riedel", written over the printed name.

i.V. Christian Riedel  
Leiter Qualitätsmanagement



**BEKO TECHNOLOGIES GMBH**  
 41468 Neuss, GERMANY  
 Tel.: +49 2131 988 0  
 www.beko-technologies.com



## EC Declaration of Conformity

We hereby declare that the products indicated hereafter comply with the stipulations of the relevant directives and technical standards. This declaration only refers to products in the condition in which they have been placed into circulation. Parts which have not been installed by the manufacturer and/or modifications which have been implemented subsequently remain unconsidered.

Product designation:	Condensate drain
Types:	BEKOMAT 31U, 32U, 32UV, 33U, 33UV
Voltage options:	95...240 VAC ±10% (50...60 Hz) / 100...125 VDC ±10% or 24...48 VAC ±10% (50...60 Hz) / 18...72 VDC ±10%
Operating pressure range:	0.8...16 bar (12...230 psi) or 1.2...16 bar (17...230psi)
Product description and function:	Condensate drain for the electronically level-controlled discharge of condensate in the compressed-air system.

**Low-Voltage Directive 2006/95/EC**

Harmonized standards applied:	EN 61010-1:2010
Year of CE labeling:	13

The devices with a supply voltage of 24...48 VAC and 18...72 VDC do not come under the scope of the Low-Voltage Directive.

**EMC Directive 2004/108/EC**

Harmonized standards applied:	EN 61326-1:2006 EN 55011:2009 + A1: 2010, group 1, class B
-------------------------------	---

**RoHS Directive 2011/65/EU**

The stipulations of the 2011/65/EU Directive on the restriction of the use of certain hazardous substances in electrical and electronic equipment are observed.

Neuss, 21 August 2013

**BEKO TECHNOLOGIES GMBH**

p.p. Christian Riedel  
 Head of Quality Department

---

## A

Accessories 23  
Accessory sets 23

## B

Blows off 21

## C

Circuit board 22  
Components 22  
Condensate discharge disturbed 21  
Control 17  
Control unit 19

## D

Danger compressed air 4, 11, 17  
Danger supply voltage 5, 14, 17  
Data 7  
Declaration of conformity 24  
Deflector area 13  
Degree of protection 5, 14, 17  
Dimension drawing 8  
Dimensions 8

## E

Electric diagram 16  
Electrical data 7  
Electrical data 7  
Electrical installation 14  
Elements 22  
Exclusion from the scope of application 6  
Exclusion of a field of application 6

## F

Failure 21  
Fault clearance 21  
Fault diagnosis 21  
Fault elimination 21  
Feed pipe 13  
Field of application 6  
Filling level 9  
Function 9

## H

Hose connector 22

## I

Inlet line 9  
Installation 11  
Installation and operating instructions 4  
Installations- und Betriebsanleitung 4  
Instructions, safety instructions 4

## L

LED does not light up 21  
LED lights continuously orange 21  
Lower part of the cover 22

## M

Maintenance 17  
Maintenance recommendation 18  
Malfunction 21  
Membrane 9  
Mounting 11

## N

No condensate discharge 21

## O

Order number 23  
Outlet line 9

## P

Piktogramme 4  
Pilot valve 9  
Pressure differences 13  
Proper use 6

## Q

Qualified personnel 5, 14, 17

## R

Recommended spare parts 23

## S

Safety instructions 4  
Self-test 9  
Sensor 22  
Sensor tube plate 20  
Service measures 4, 11, 17  
Service unit 18, 22  
Sets of spare parts 23  
Slope 13  
Spare parts 5, 23  
Symbole 4

## T

Technical data 7  
Troubleshooting 21

## U

Upper part of the cover 22

## V

Venting line 13

## W

Water pocket 13



**Headquarter :**

**Deutschland / Germany**

BEKO TECHNOLOGIES GMBH  
Im Taubental 7  
D-41468 Neuss  
Tel. +49 2131 988 0  
beko@beko-technologies.com

**中华人民共和国 / China**

BEKO TECHNOLOGIES (Shanghai)  
Co. Ltd.  
Rm.606 Tomson Commercial Building  
710 Dongfang Rd.  
Pudong Shanghai China  
P.C. 200122  
Tel. +86 21 508 158 85  
info.cn@beko-technologies.cn

**France**

BEKO TECHNOLOGIES S.à.r.l.  
Zone Industrielle  
1 rue des Frères Rémy  
F- 57200 Sarreguemines  
Tél. +33 387 283 800  
info@beko-technologies.fr

**India**

BEKO COMPRESSED AIR  
TECHNOLOGIES Pvt. Ltd.  
Plot No.43/1, CIEEP, Gandhi Nagar,  
Balanagar, Hyderabad - 500 037, INDIA  
Tel. +91 40 23080275  
eric.purushotham@bekoindia.com

**Italia / Italy**

BEKO TECHNOLOGIES S.r.l  
Via Peano 86/88  
I - 10040 Leini (TO)  
Tel. +39 011 4500 576  
info.it@beko-technologies.com

**日本 / Japan**

BEKO TECHNOLOGIES K.K  
KEIHIN THINK 8 Floor  
1-1 Minamiwatarida-machi  
Kawasaki-ku, Kawasaki-shi  
JP-210-0855  
Tel. +81 44 328 76 01  
info@beko-technologies.jp

**Benelux**

BEKO TECHNOLOGIES B.V.  
Veenen 12  
NL - 4703 RB Roosendaal  
Tel. +31 165 320 300  
benelux@beko-technologies.com

**Polska / Poland**

BEKO TECHNOLOGIES Sp. z o.o.  
ul. Chłapowskiego 47  
PL-02-787 Warszawa  
Tel +48 22 855 30 95  
info.pl@beko-technologies.pl

**Scandinavia**

www.beko-technologies.com

**España / Spain**

BEKO Tecnológica España S.L.  
Torruella i Urpina 37-42, nave 6  
E-08758 Cervello  
Tel. +34 93 632 76 68  
info.es@beko-technologies.es

**South East Asia**

BEKO TECHNOLOGIES S.E.Asia  
(Thailand) Ltd.  
75/323 Romkiao Road  
Sansab, Minburi  
Bangkok 10510  
Thailand  
Tel. +66 2-918-2477  
info.th@beko-technologies.com

**臺灣 / Taiwan**

BEKO TECHNOLOGIES Co.,Ltd  
16F.-5, No.79, Sec. 1,  
Xintai 5th Rd., Xizhi Dist.,  
New Taipei City 221,  
Taiwan (R.O.C.)  
Tel. +886 2 8698 3998  
peter.huang@beko-technologies.tw

**Česká Republika / Czech Republic**

BEKO TECHNOLOGIES s.r.o.  
Na Pankraci 1062/58  
CZ - 140 00 Praha 4  
Tel. +420 24 14 14 717  
info@beko-technologies.cz

**United Kingdom**

BEKO TECHNOLOGIES LTD.  
2 & 3 West Court  
Buntsford Park Road  
Bromsgrove  
GB-Worcestershire B60 3DX  
Tel. +44 1527 575 778  
info@beko-technologies.co.uk

**USA**

BEKO TECHNOLOGIES CORP.  
900 Great SW Parkway  
US - Atlanta, GA 30336  
Tel. +1 404 924-6900  
beko@bekousa.com

Translation of the original manual/instructions.

Original instructions are in German

Subject to technical modifications without notice / errors accepted.

BM31U\_built\_in\_F\_uc\_manual\_en-us\_2014\_08.

Printed in Germany