



US-EN - US-english

Instructions for installation and operation

Pressure dew point transmitter METPOINT® DPM

SD11



Dear customer,

Thank you for deciding in favor of the METPOINT® DPM SD11 pressure dew point transmitter. Please read these installation and operating instructions carefully before mounting and starting up the pressure dew point transmitter and follow our directions.

Perfect functioning of the pressure dew point transmitter can only be guaranteed when the provisions and notes stipulated here are strictly adhered to.

Contents

1	Pictograms and symbols	4
2	Signal words in accordance with ISO 3864 and ANSI Z 535.....	4
3	General information.....	5
4	Safety instructions	6
5	Proper use.....	7
5.1	Exclusion from the field of application.....	7
6	Type plate.....	8
7	Technical data	9
8	Dimension drawings.....	12
9	Function.....	14
10	Installation	15
10.1	Installation instructions	15
10.2	Preparing the pressure dew point transmitter	16
10.3	Installation in the measuring chamber	16
11	Electrical installation.....	17
11.1	Connection DPM SD11, 2-wire system, Current output 4 ... 20 mA	18
12	Maintenance and calibration	19
12.1	Cleaning/decontamination.....	20
13	Scope of delivery.....	21
14	Accessories	22
15	Dismantling and disposal	23
16	Troubleshooting and fault removal.....	23
17	Declaration of conformity	24
18	Index.....	26

Pictograms and symbols

1 Pictograms and symbols



Observe the installation and operating instructions



General advice



Observe the installation and operating instructions
(on the type plate)



General danger symbol (danger, warning, caution)



Use protective gloves

2 Signal words in accordance with ISO 3864 and ANSI Z 535

Danger!	Imminent hazard Consequences of non-observance: serious injury or death
Warning!	Potential hazard Consequences of non-observance: possible serious injury or death
Caution!	Imminent hazard Consequences of non-observance: possibly injury or property damage
Notice!	Potential hazard Consequences of non-observance: possibly injury or property damage
Important!	Additional advice, info, hints Consequences of non-observance: disadvantages during operation and maintenance, no danger

3 General information

**Warning!****Risk of injury when used incorrectly!**

Prior to the mounting, start-up, and operation of the pressure dew point transmitter, it must be ensured that the device was correctly chosen with regard to the measuring range, design and specific measurement conditions. In the event of non-observance, severe personal injury and/or damage to materials may occur.

**Warning!****Risk of injury in the event of insufficient qualifications!**

Improper use can lead to significant personal injury and material damage. All of the activities described in these operating instructions must only be carried out by qualified personnel with the qualifications described hereinafter.

Qualified personnel

Due to the specific training and knowledge concerning the measuring and control technology, and due to their experience and knowledge of the country-specific provisions, standards in force and directives, qualified personnel are capable of carrying out the described work and of independently identifying the possible risks. Special employment conditions require further corresponding knowledge, e.g. regarding aggressive media.



Please check, prior to reading the operating instructions, whether or not these instructions correspond to the device. Read these installation and operating instructions carefully prior to any intervention regarding the METPOINT® DPM. The operating instructions must be accessible at all times at the place of application of the device.

If you have any queries regarding these instructions, please contact BEKO TECHNOLOGIES.

Installation works must exclusively be carried out by authorized and qualified personnel. Prior to undertaking any measures, the qualified personnel shall read up on the device by carefully studying the operating instructions. The operator of the products is responsible for the adherence to these provisions. The respective directives in force apply to the qualification and expertise of the qualified personnel.

For safe operation, the device must only be installed and operated in accordance with the indications in the operating instructions. In addition, the national and operational statutory provisions and safety regulations, as well as the accident prevention regulations required for the respective case of application, need to be observed during employment. This applies accordingly when accessories are used.

**Important:**

Keep all the packaging materials of the pressure dew point transmitter, since these will be required for the further installation and return.

Safety instructions

4 Safety instructions



Danger!
Compressed air!

Risk of serious injury or death through contact with quickly or suddenly escaping compressed air or through bursting plant components.

Measures

- Do not exceed the max. operating pressure (see type plate)!
- Only use pressure-resistant installation material!
- Make sure that no persons or objects can be hit by emerging compressed air!



Danger!
Inadmissible operating parameters!

Under-running or exceeding the limit values involves risks for persons and the material, and malfunction and service failures may occur.

Measures

- Make sure that the pressure dew point transmitter is operated only within the permissible limit values that are indicated on the type plate and in the technical data.
- Exact compliance with the performance data of the pressure dew point transmitter in connection with the case of application.
- Carry out service and calibration measures at regular intervals.

Further safety advice

- During installation and operation, the national regulations and safety instructions in force also need to be observed.
- The pressure dew point transmitter must not be employed in hazardous areas.

Additional instructions

- Do not overheat the device!
- The pressure dew point transmitter must not be disassembled!



Caution!
Possible damage!

Using the pressure dew point transmitter with corrosive media involves the risk of premature mechanical failure.

Measures

- Only use the device with the media that are listed in the data sheet and in the technical data.



Note:

The resistance at the 1.5 times permissible max. operating pressure is confirmed.
For further information, please refer to the enclosed technical data sheet.

5 Proper use

The **METPOINT® DPM** pressure dew point transmitter is intended for the measurement of the pressure dew point in **gaseous** media. The pressure dew point transmitter transforms the measured value into a linear, analog 4 ... 20 mA output signal.

The application is restricted to compressed air and inert gases of fluid group 2 in accordance with the 97/23/EC Pressure Equipment Directive.

The max. permissible operating pressure is 725 psig (50 bar [ü]) and the temperature of the process medium must not exceed the range between -22 °F and +158 °F (-30 °C and +70 °C).

The **METPOINT® DPM** pressure dew point transmitter is exclusively designed and constructed for the proper application purpose that is described herein and must be used correspondingly.

A check in order to ascertain whether or not the device is suitable for the chosen employment must be carried out by the user. It must be ensured that the medium is compatible with the components which come into contact with it. **The technical data listed in the data sheet are binding.**

Improper handling or operation outside the technical specifications is impermissible. **Claims of any kind on the basis of improper use are excluded.**

5.1 Exclusion from the field of application

- The device is **not** suitable for use in hazardous areas.
- The device is **not** suitable for application with corrosive gases.
- Improper handling or operation outside the technical specifications.

Type plate

6 Type plate

The type plate is on the housing. It includes all the important data regarding the METPOINT® DPM pressure dew point transmitter which must be communicated to the manufacturer or supplier upon request.

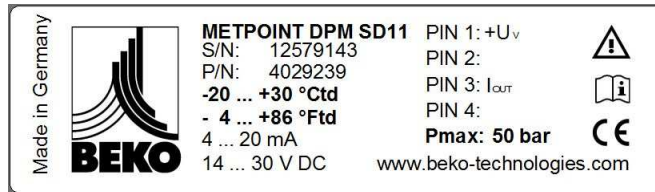

METPOINT® DPM SD11	Product designation
S/N:	Serial number
P/N:	Item number
-20 ... +30 °C_{td}	Measuring range
-4 ... +86 °F_{td}	
4 ... 20 mA	Power supply
PIN 1:	Power supply (+U _v)
PIN 2:	Not used
PIN 3:	Current output (-I _{OUT})
PIN 4:	Not used
Pmax:	50 bar (725 psi)



Note:

Never remove, damage, or obliterate the type plate!

7 Technical data

	
General indications	
Model designation	DPM SD11
Measuring principle	Capacitive polymer sensor
Measured parameter	°F _{td} / °C _{td} , dew point/freezing point
Measuring range	-4 ... +86 °F_{td} (-20 ... +30 °C_{td})
Output signal	4 ... 20 mA , analog, 2-wire
Max. permissible operating overpressure	725 psig (50 bar [ü])
Process medium ¹	Compressed air
Temperature-compensated range	-13 ... +140 °F (-25 ... +60 °C)
Reference conditions ^{2,3}	EN 61298-1
Process connection	G ½ external thread (ISO 228-1)
Sensor protection	Stainless steel sintered filter 40 µm
Measuring gas flow when the measuring chamber is employed	0.04 ... 0.11 scfm (1 ... 3 standard l/min.)
Weight	6.2 oz (175 g)
Degree of protection according to EN 60529 ⁴	IP 65

¹ **Process medium**

Compressed air, nitrogen, and other gases of group 2 according to Article 9, Clause 2.2 of the PED 97/23/EC. Group 2 comprises fluids which are **not** toxic, corrosive, flammable, potentially explosive, and fire-promoting.

The process medium must be compatible with the material 1.4404 and the other materials which come into contact with the medium (see Table: materials).

² **The tests are carried out under ambient conditions in accordance with EN 61298-1.**

- Temperature: 59 ... 77 °F (15 ... 25 °C)
- Air pressure: 12 ... 15 psi (860 ... 1060 mbar)
- Air humidity: 45 ... 75% relative

The max. permissible deviation of the ambient temperature must not exceed 33 °F (1 °C) in 10 min. for each test, and maximally 37 °F/h (3 °C/h).

³ The max. error of measurement refers to the calibration of the pressure dew point transmitters with the medium compressed air under the following reference conditions:

- Compressed-air temperature: +68 °F (+20 °C)
- Operating pressure: 72 psi (5.0 bar (abs))

⁴ The indicated protection classes according to EN 60529 only apply when connected, with a mating connector with a corresponding protection class.

Technical data

Materials	
Sensor element (in contact with the medium)	Polymer, aluminum oxide, Ni, Cr, Au, Ag, Cu, Pt, Sn
Glass feedthrough (in contact with the medium)	1.4301, 2.4478 (NiFe), Au, FKM/EPDM
Process connection (in contact with the medium)	1.4404, EN 10272, EN 10088-3
Housing	1.4404, EN 10272, EN 10088-3
Mounting connector (Phoenix, item no. 1557581)	CuZn, Au, PA 66, FKM / EPDM

Permissible temperature ranges	
Process-medium temperature	-22 °F ... 158 °F (-30 °C ... +70 °C)
Ambient temperature during operation	-13 °F ... 140 °F (-25 °C ... +60 °C)
Storage and transport temperature	-40 °F ... 185 °F (-40 °C ... +85 °C)
Ambient humidity	0...95%, non-condensing

Accuracy	
Max. error of measurement ¹	± 2 K for -4 ... +14 °F _{td} (-20 ... -10 °C _{td}) ± 1 K for +14 ... +86 °F _{td} (-10 ... +30 °C _{td})
Response time	< 10 sec. from dry to wet
	< 40 sec. from wet to dry
Measuring rate	1 measurement per 2 seconds

CE conformity	
Pressure Equipment Directive ²	97/23/EC
EMC Directive	2004/108/EC
EMC immunity to interference, industrial field	EN 61326-1 & EN 61326-2-3
EMC emitted interference (emission), group 1, class B	EN 61326-1
CE labelling according to the EMC Directive 2004/108/EC	

¹ Max. error of measurement at reference conditions.

² For gases and fluids of fluid group 2, the requirements according to Article 3, Clause 3 (good engineering practice) are met.

Electrical connections	
Connector (cable box) according to EN 61076-2-101	M12 x1 (4-pole)
Type of connection	Screw terminals
Wire cross-section	Max. 0.75 mm ² (AWG 18)
Grommet	0.2 ... 0.3 inch (4 ... 6 mm)
Degree of protection	IP 67 according to EN60529

Electrical specifications DPM SD11	
Supply voltage ¹ U_V	14 ... 30 V DC
Max. power consumption during nominal operation	720 mW
Current consumption ² during nominal operation	Max. 24 mA
Load (load resistance) R_L	$R_L = \text{max. } 416 \Omega \text{ at } 24 \text{ V DC}$
Resistance to short-circuiting	Permanent
Reverse voltage protection	Available
Insulation resistance, EN 61298-2, Clause 6.3.2	> 100 M Ω at 500V DC
Voltage proof, EN 61298-2, Clause 6.3.3	500 V AC
Overvoltage arrester ³	33 V DC

¹ **The nominal value of the supply voltage is 24 V DC.**

Supply to the pressure transducer should be implemented with a stabilized, short-circuit-protected power supply that is protected against overvoltage.

The energy supply to the pressure transducer must come from a source with an **energy-limited electrical circuit** (10 A max./ 30 V max.) and a protective separation from the network. **See EN 61010-1, Clause 9.4.**

² Reverse voltage protection.

In the event that the connections are interchanged, the transmitter may be damaged under certain circumstances. It is imperative to observe the connection diagrams.

³ Overvoltage arrester. The overvoltage is limited at 33 V DC by the suppressor diode.

Dimension drawings

8 Dimension drawings

Dimensions DPM SD11

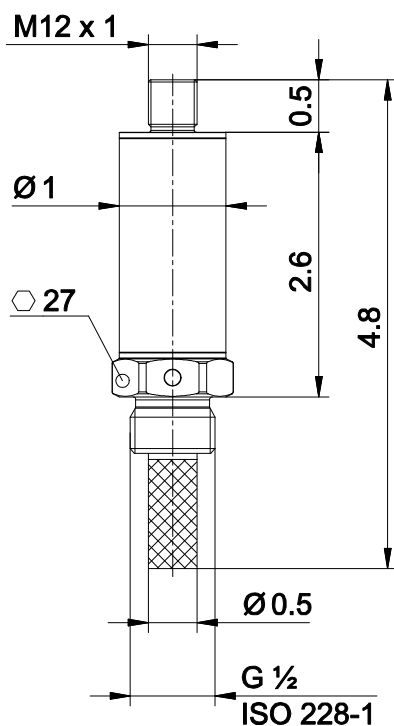

Dimensions DPM SD11 with a connecting plug (straight)

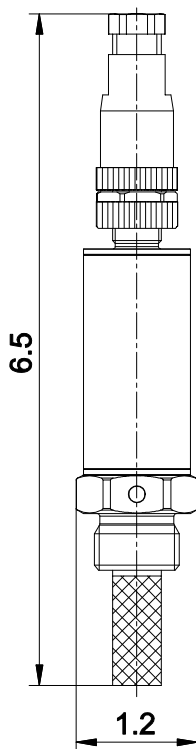

Dimensions DPM SD11 with a connecting plug (angle)

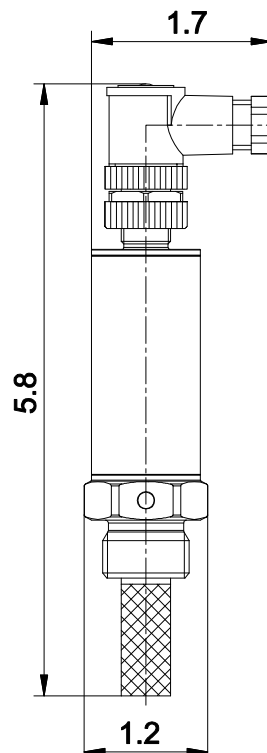

Standards for threads

Straight pipe thread (internal and external screw thread) for a non-sealing connection in the thread
Short symbol **G**, according to **ISO 228-1**

Dimensions measuring chamber Basic

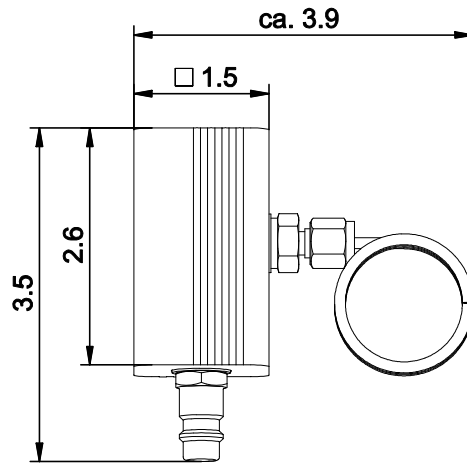

Dimensions measuring chamber Vario with a purge-air controller

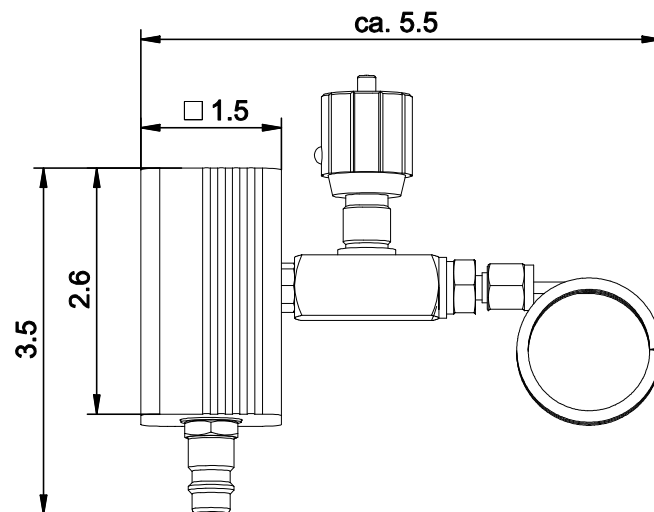

Function

9 Function

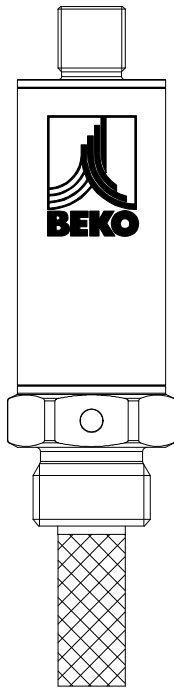

The transmitter is equipped with a **G 1/2"** fixing thread according to ISO 228 and can directly be screwed into the measuring chamber. Alternatively, direct installation in the measuring line is also possible.

During the production of the **METPOINT® DPM SD11**, calibration is implemented at 20 measuring points. The employed reference devices are traceable to the national norms of the Physikalisch-Technische Bundesanstalt (national metrology institute).

10 Installation

10.1 Installation instructions



Warning!

Risk of injury in the event of insufficient qualifications!

Improper use can lead to significant personal injury and material damage. All of the activities described in these operating instructions must only be carried out by qualified personnel with the qualifications described hereinafter.

Qualified personnel

Due to the specific training and knowledge concerning the measuring and control technology, and due to their experience and knowledge of the country-specific provisions, standards in force and directives, qualified personnel are capable of carrying out the described work and of independently identifying the possible risks. Special employment conditions require further corresponding knowledge, e.g. regarding aggressive media.



Danger!

Compressed air!

Risk of serious injury or death through contact with quickly or suddenly escaping compressed air or through bursting and/or unsecured plant components.

Measures:

- **Only carry out installation works when the system is pressureless.**
- Only use pressure-resistant installation material.
- Do not exceed the max. operating pressure (see type plate).
- Check the installation point for tightness subsequent to installation.



Warning!

Risk of injury through temperature!

Risk of injury through the contact with very high or low temperatures.



Measures:

- Prior to installation or removal of the pressure dew point transmitter, carry out a temperature compensation or wear protective gloves.



Caution!

Malfunction at the pressure dew point transmitter!

Through incorrect installation, malfunctions may occur at the METPOINT® DPM SD11 pressure dew point transmitter. These can lead to incorrect measuring results and to misinterpretations.



Note:

It is imperative to observe all of the listed hazard and warning notes.

Please also observe all the provisions and instructions regarding the occupational safety and fire at the respective point of installation.

As a matter of principle, only use suitable tools and material in a proper condition.

Bear in mind that condensates can contain aggressive and harmful components. Therefore, avoid contact with the skin.

Installation

10.2 Preparing the pressure dew point transmitter

The **METPOINT® DPM SD11** pressure dew point transmitter is delivered by the factory in a protection chamber. The latter protects the transmitter against damage and high humidity.

1. Unscrew the pressure dew point transmitter (3) in the anti-clockwise direction from the protection chamber.
2. Protect the sealing ring (2) against loss when unscrewing the transmitter and keep it ready for the installation in the measuring chamber.
3. The protection chamber (1) and the contained desiccant must be kept for the return transport of the transmitter.

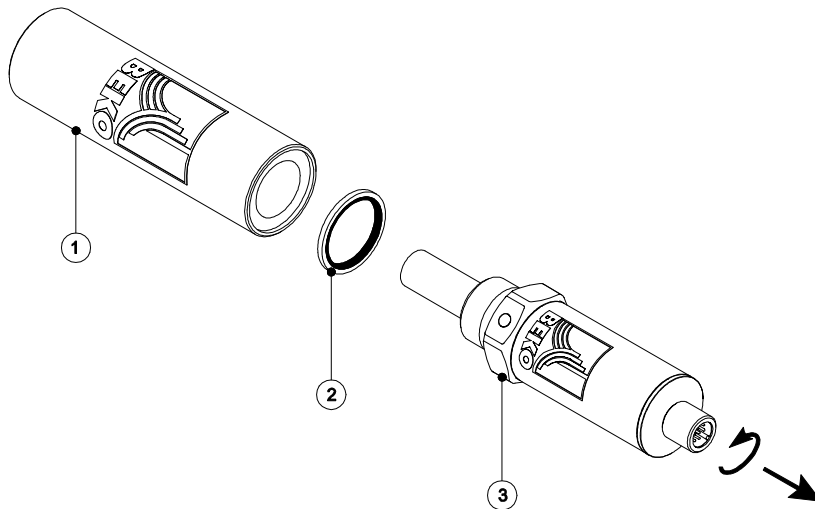

10.3 Installation in the measuring chamber

Firmly screw the pressure dew point transmitter (3) with the sealing ring (2) into the measuring chamber (4) or (5), and then check for tightness.

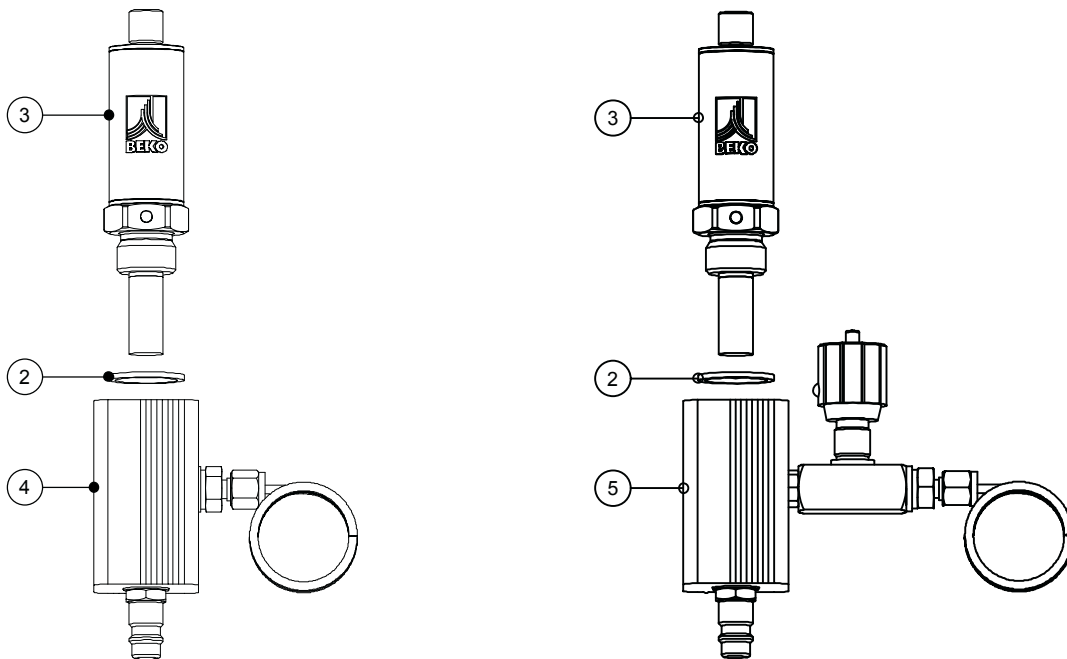

Note:

The max. permissible operating pressure and the operating temperature of the measuring chamber can be taken from the type plate of the respective measuring chamber.

11 Electrical installation

Prior to the installation and start-up, the maximum load resistance must be observed. With a nominal value of the supply voltage of **24 V DC**, the max. load resistance is 416 Ω. With a supply voltage that deviates from 24 V DC, the max. load resistance can be calculated according to the following formula:

$$R_L \leq (U_v - 14 \text{ V}) / 0.024 \text{ A } [\Omega]$$



Warning!

Risk of injury in the event of insufficient qualifications!

Improper use can lead to significant personal injury and material damage. All of the activities described in these operating instructions must only be carried out by qualified personnel with the qualifications described hereinafter.

Qualified personnel

Due to the specific training and knowledge concerning the measuring and control technology, and due to their experience and knowledge of the country-specific provisions, standards in force, and directives, qualified personnel are capable of carrying out the described work and of independently identifying the possible risks.

Special employment conditions require further corresponding knowledge, e.g. regarding aggressive media.

Connector, M12 x 1, 4-pole, a-coded		
Arrangement of the poles plug View transmitter side	Arrangement of the poles - fe- male connector View female connector side	Arrangement of the poles female connector View screwing side

The cable must be assembled as follows:

1. Push the components of the plug connector over the cable
2. Cut the cable jacket by 0.8 inch (20 mm) in length
3. Cut the conductor sheath by 0.2 inch (5 mm) in length
4. Introduce the cable into the connector according to the pin assignment
5. Assemble/screw together the components of the connector

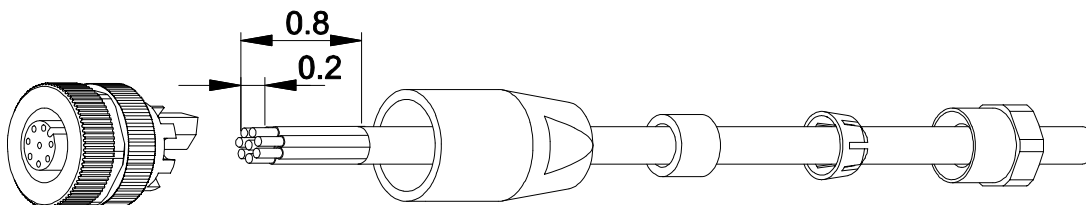

It is recommended to use a shielded cable for the installation. Shielding is implemented via the shield ring of the connector. The preconditions are that the respective connector is made of metal and that the shield has the shape of a braid. The shielding should be earthed at one end.

Electrical installation

11.1 Connection DPM SD11, 2-wire system, Current output 4 ... 20 mA

Pin	Function	Description	Conductor coloring
PIN-1	+U _V	Positive (+) connection of the supply voltage	Brown
PIN-3	+I _{OUT}	Current output	White
PIN-4		Not used	
PIN-2		Not used	

Connection diagram DPM SD 11, 4-wire system, current output 4 ... 20 mA

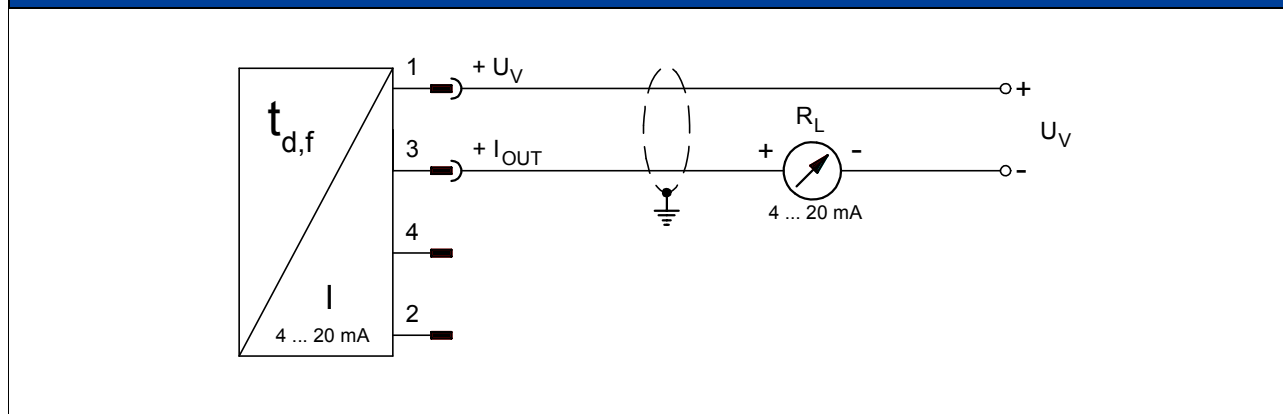

Notes:

The analog current output 4 ... 20 mA has no potential isolation to the power supply.

The **METPOINT® DPM SD11** pressure dew point transmitters are supplied ex works with a 4 ... 20 mA current output. The following scaling was configured in the factory:

$$4 \text{ mA} = -4 \text{ }^{\circ}\text{F}_{\text{td}} (-20 \text{ }^{\circ}\text{C}_{\text{td}})$$

$$20 \text{ mA} = +86 \text{ }^{\circ}\text{F}_{\text{td}} (+30 \text{ }^{\circ}\text{C}_{\text{td}})$$

The output of the current signal takes place at PIN-3 of the 4-pole M12 connector.

For the connection to superordinate control systems, an isolation amplifier may be required in order to avoid earth-coupling. In this respect, please contact the manufacturer of the superordinate control system regarding the possible specifications.

12 Maintenance and calibration

The perfect and safe functioning of the components requires calibration or adjustment at regular intervals.

The METPOINT® DPM SD11 should be calibrated annually by the manufacturer, and re-adjusted, if required.



Danger!

Compressed air!

Risk of serious injury or death through contact with quickly or suddenly escaping compressed air or through bursting and/or unsecured plant components.

Measures:

- **Only carry out installation works when the system is pressureless and deactivated.**
- Only use pressure-resistant installation material.
- Make sure that no persons or objects can be hit by condensate or emerging compressed air.
- Check the tightness subsequent to maintenance measures.



Warning!

Risk of injury in the event of insufficient qualifications!

Improper use can lead to significant personal injury and material damage.

All of the activities described in these operating instructions must only be carried out by qualified personnel with the qualifications described hereinafter.

Qualified personnel

Due to the specific training and knowledge concerning the measuring and control technology, and due to their experience and knowledge of the country-specific provisions, standards in force and directives, qualified personnel are capable of carrying out the described work and of independently identifying the possible risks.

Special employment conditions require further corresponding knowledge, e.g. regarding aggressive media.



Warning!

Risk of injury through temperature!



Risk of injury through the contact with very high or low temperatures.

Measures:

- Prior to undertaking maintenance measures, carry out a temperature compensation or wear protective gloves.



Caution!

Damage possible!

Damage and malfunctions at the METPOINT® DPM SD11 pressure dew point transmitter may occur through incorrect maintenance and calibration or when maintenance and calibration measures are not undertaken at regular intervals.

These can lead to incorrect measuring results and to misinterpretations.

Measures:

- Carry out regular inspections and checks in accordance with the Pressure Equipment Directive (PED).

Maintenance and calibration

12.1 Cleaning/decontamination

Cleaning of the METPOINT® DPM SD11 must be undertaken using a slightly damp (not wet) cotton cloth or one-way wipe, and mild, commercially available cleaner/soap.

For decontamination, spray the cleaner on an unused cotton cloth or one-way wipe and wipe the component comprehensively. Effectuate subsequent drying using a clean cloth or via air drying.

In addition, the local hygiene provisions need to be observed.



Danger!

Compressed air/reaction products!



Risk of serious injury or death through contact with quickly or suddenly escaping compressed air and through toxic, flammable, or potentially explosive reaction products.

Measures:

- **Only carry out cleaning measures when the system is pressureless.**
- Purge the respective plant component or pressure dew point transmitter prior to starting the maintenance works.
- Immediately clean the removed components from measuring media residues.



Warning!

Damage possible!

A too high degree of humidity and hard and pointed objects cause damage to the pressure transducer and to the integrated electronic components.

Measures

- Never clean with a soaked cloth.
- Do not use pointed or hard objects for cleaning.

13 Scope of delivery

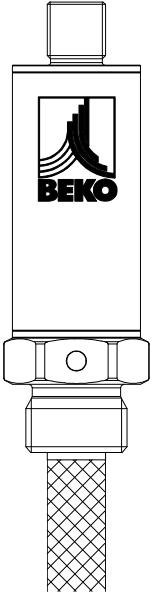
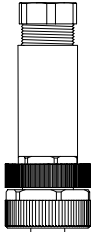
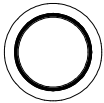
Illustration	Description
	<p>1 x METPOINT® DPM SD11 pressure dew point transmitter</p>
	<p>1x M12 plug, straight</p>
	<p>1 x stainless-steel seal</p>
<p>Without illustration</p>	<p>1 x factory calibration record</p>

Accessories

14 Accessories

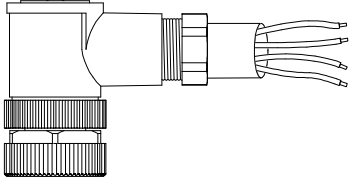
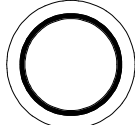
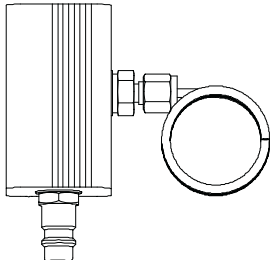
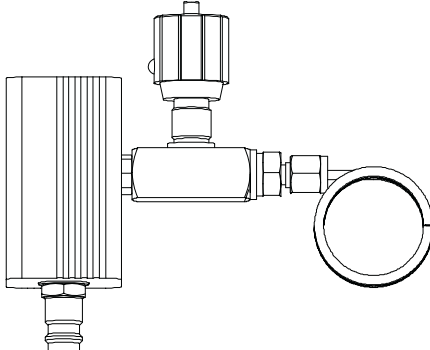
Description	Order no.
<p>M12 connector, angle (incl. 16.4 ft (5 m) cable, pre-assembled)</p>  <p>A technical drawing of an M12 connector. It features a rectangular metal housing with a threaded section on the left side. A cable with four individual conductors is attached to the right side of the housing.</p>	<p>4025252</p>
<p>1 x stainless-steel seal</p>  <p>A technical drawing of a stainless-steel seal, which is a circular ring with a raised outer edge and a recessed inner edge.</p>	<p>4025004</p>
<p>Measuring chamber "Basic"</p>  <p>A technical drawing of a measuring chamber. It consists of a vertical rectangular chamber with a threaded port at the bottom. A circular stainless-steel seal is shown to the right of the chamber, which is used to seal the top of the chamber.</p>	<p>232 psi (16 bar) : 4026170 725 psi (50 bar) : 4027290</p>
<p>Measuring chamber with a purge-air controller "VARIO"</p>  <p>A technical drawing of a measuring chamber with a purge-air controller. It features a vertical rectangular chamber with a threaded port at the bottom. A purge-air controller, which is a cylindrical component with a top cap, is mounted on top of the chamber. A circular stainless-steel seal is shown to the right of the chamber.</p>	<p>232 psi (16 bar) : 4026171 725 psi (50 bar) : 4027291</p>

15 Dismantling and disposal

When dismantling the DPM SD11 pressure dew point transmitter, all the related parts and operating media must be disposed of separately.

Waste code:

20 01 36

Used electrical and electronic devices with the exception of those which come under 20 01 21, 20 01 23, and 20 01 35.



Warning!

Danger for persons and the environment!

The device must be disposed of in accordance with the European RoHS-2 2011/65/EU Directive.

Old appliances must not be disposed of with normal household waste!

Depending on the used medium, residues on the device may represent a danger to the operator or the environment. Therefore, undertake suitable protective measures and dispose of the device properly.

Measures:

- Immediately clean the removed components from measured media residues when suitable protective measures cannot be undertaken.



Warning!

Risk of injury!



Risk of injury through the contact with very high or low temperatures.

Measures:

- Prior to the removal of the DPM SD11 pressure dew point transmitter, wait for temperature compensation or wear protective gloves.

16 Troubleshooting and fault removal

Symptoms	Possible reasons
Signal current ≥ 21.0 mA	Sensor error / system error
Signal current ≤ 3.6 mA	Sensor error / system error
Signal current < 4.0 to 3.8 mA	Falling below the measuring range
Signal current > 20.0 to 20.5 mA	Exceeding the measuring range
There is no signal. Signal current = 0 mA	Break of the signal line

Declaration of conformity

17 Declaration of conformity

BEKO TECHNOLOGIES GMBH
41468 Neuss, GERMANY
Tel: +49 2131 988-0
www.beko-technologies.de



EG-Konformitätserklärung

Wir erklären hiermit, dass die nachfolgend bezeichneten Produkte den Anforderungen der einschlägigen Richtlinien und technischen Normen entsprechen. Diese Erklärung bezieht sich nur auf die Produkte in dem Zustand, in dem sie von uns in Verkehr gebracht wurden. Nicht vom Hersteller angebrachte Teile und/oder nachträglich vorgenommene Eingriffe bleiben unberücksichtigt.

Produktbezeichnung:	METPOINT® DPM SD11
Typ:	4029239
Messbereich:	-20 ... +30 °C td (Frostpunkt / Taupunkt)
Versorgungsspannung:	14 ... 30 V DC
Datenblatt:	DPM-850-0314-FP-A
Zeichnungs-Nr.:	00181-T01-R05; 00182-T01-R05; 00182-T03-R06; 00181-T02-R02; 00113-090602
Max. zulässige Betriebsüberdruck:	50 bar
Min. / Max. Betriebstemperatur:	-30°C / +70°C
Produktbeschreibung und Funktion:	Drucktaupunkt-Transmitter

Druckgeräte-Richtlinie 97/23/EG

Die Produkte fallen in keine Druckgerätekategorie und sind gemäß Artikel 3 Absatz 3 in Übereinstimmung mit der in den Mitgliedstaaten geltenden guten Ingenieurspraxis ausgelegt und werden dieser entsprechend hergestellt.

EMV-Richtlinie 2004/108/EG

Angewandte Normen:	EN 61010-1:2010, EN 61326-1:2006,
	EN 61326-2-3:2006, EN 55011:2009+A1:2010

ROHS II-Richtlinie 2011/65/EU

Die Vorschriften der Richtlinie 2011/65/EU zur Beschränkung der Verwendung bestimmter gefährlicher Stoffe in Elektro- und Elektronikgeräten werden erfüllt.

Die Produkte sind mit dem abgebildeten Zeichen gekennzeichnet:



Neuss, 13.04.2015

BEKO TECHNOLOGIES GMBH

A blue ink signature of Christian Riedel, written in a cursive style.

i.V. Christian Riedel
Leiter Qualitätsmanagement

Archiving: DPMSD11-823-0415-FP-A

BEKO TECHNOLOGIES GMBH
41468 Neuss, GERMANY
Tel.: +49 (0)2131 988 0
www.beko-technologies.com



EC Declaration of Conformity

We hereby declare that the products listed below comply with the stipulations of the relevant directives and technical standards. This declaration relates only to the products in the condition in which we put them on the market. Parts that were not installed by the manufacturer and/or alterations that have been made subsequently are not taken into account.

Product name:	METPOINT® DPM SD11
Type:	4029239
Measuring range:	-20 – +30°C Td (freezing point/dew point)
Supply voltage:	14 – 30 V D C
Data sheet:	DPM-850-0314-FP-A
Drawing numbers:	00181-T01-R05; 00182-T01-R05; 00182-T03-R06; 00181-T02-R02; 00113-090602
Max. permissible operating pressure:	50 bar
Min./max. operating temperature:	-30°C/+70°C
Product description and function:	Pressure dew point transmitter

Pressure Equipment Directive 97/23/EC

The products do not come under any pressure equipment category and are designed in accordance with the good engineering practices applicable in the member states as per Article 3 Paragraph 3, and are manufactured accordingly.

EMC Directive 2004/108/EC

Applicable standards: EN 61010-1:2010, EN 61326-1:2006,
EN 61326-2-3:2006, EN 55011:2009+A1:2010

RoHS II Directive 2011/65/EU

The stipulations of Directive 2011/65/EU on the restriction of the use of certain hazardous substances in electrical and electronic equipment have been complied with.

The products have been labeled with the marking shown below:



Neuss, 13/04/2015

BEKO TECHNOLOGIES GMBH

p.p. Christian Riedel
Head of Quality Management

Archiving: DPMSD11-823-0415-FP-A

18 Index

- Accessories 22
- Check 19
- Components 21
- Connection SD21, 4 ... 20 mA 18
- Danger compressed air** 5, 15, 17, 19, 20, 23
- Declaration of conformity 24
- Description SD21 14
- Dimension drawing and connections SD21 14
- Dimension drawings 12
- Dimensions 12, 14
- Dimensions SD21 12
- Electrical data 11
- Electrical installation 17
- Exclusion from the field of application 7
- Fault 23
- Fault clearance 23
- Fault removal 23
- Function 14
- Installation and operating instructions 4
- Maintenance 19
- Maintenance works** 15, 20
- Malfunction 23
- Pictograms 4
- Scope of delivery 21
- Symbols 4
- Technical data 9
- Technical data SD21 9
- Troubleshooting 23

<p>Headquarter :</p> <p>Deutschland / Germany BEKO TECHNOLOGIES GMBH Im Taubental 7 D-41468 Neuss Tel. +49 2131 988 0 beko@beko-technologies.com</p>	<p>中华人民共和国 / China BEKO TECHNOLOGIES (Shanghai) Co. Ltd. Rm.606 Tomson Commercial Building 710 Dongfang Rd. Pudong Shanghai China P.C. 200122 Tel. +86 21 508 158 85 Info.cn@beko-technologies.cn</p>	<p>France BEKO TECHNOLOGIES S.à.r.l. Zone Industrielle 1 rue des Frères Rémy F- 57200 Sarreguemines Tél. +33 387 283 800 info@beko-technologies.fr</p>
<p>India BEKO COMPRESSED AIR TECHNOLOGIES Pvt. Ltd. Plot No.43/1, CIEEP, Gandhi Nagar, Balanagar, Hyderabad - 500 037, INDIA Tel. +91 40 23080275 eric.purushotham@bekoindia.com</p>	<p>Italia / Italy BEKO TECHNOLOGIES S.r.l Via Peano 86/88 I - 10040 Leini (TO) Tel. +39 011 4500 576 info.it@beko-technologies.com</p>	<p>日本 / Japan BEKO TECHNOLOGIES K.K KEIHIN THINK 8 Floor 1-1 Minamiwatarida-machi Kawasaki-ku, Kawasaki-shi JP-210-0855 Tel. +81 44 328 76 01 info@beko-technologies.jp</p>
<p>Benelux BEKO TECHNOLOGIES B.V. Veenen 12 NL - 4703 RB Roosendaal Tel. +31 165 320 300 benelux@beko-technologies.com</p>	<p>Polska / Poland BEKO TECHNOLOGIES Sp. z o.o. ul. Chłapowskiego 47 PL-02-787 Warszawa Tel +48 22 855 30 95 info.pl@beko-technologies.pl</p>	<p>Scandinavia www.beko-technologies.com</p>
<p>España / Spain BEKO Tecnológica España S.L. Torruella i Urpina 37-42, nave 6 E-08758 Cervello Tel. +34 93 632 76 68 info.es@beko-technologies.es</p>	<p>South East Asia BEKO TECHNOLOGIES S.E.Asia (Thailand) Ltd. 75/323 Romklao Road Sansab, Minburi Bangkok 10510 Thailand Tel. +66 2-918-2477 info.th@beko-technologies.com</p>	<p>臺灣 / Taiwan BEKO TECHNOLOGIES Co.,Ltd 16F.-5, No.79, Sec. 1, Xintai 5th Rd., Xizhi Dist., New Taipei City 221, Taiwan (R.O.C.) Tel. +886 2 8698 3998 Info.tw@beko-technologies.tw</p>
<p>Česká Republika / Czech Republic BEKO TECHNOLOGIES s.r.o. Na Pankraci 1062/58 CZ - 140 00 Praha 4 Tel. +420 24 14 14 717; 24 14 09 333 info@beko-technologies.cz</p>	<p>United Kingdom BEKO TECHNOLOGIES LTD. 2 West Court Buntsford Park Road Bromsgrove GB-Worcestershire B60 3DX Tel. +44 1527 575 778 info@beko-technologies.co.uk</p>	<p>USA BEKO TECHNOLOGIES CORP. 900 Great SW Parkway US - Atlanta, GA 30336 Tel. +1 404 924-6900 beko@bekousa.com</p>

Original instructions in German.

Subject to technical changes / errors excepted.

metpoint_SD11_manual_en-us_10-112_1501_v01