



EN-US - english US

Instructions for installation and operation

Condensate drain

BEKOMAT® 32U Vario built-in F (BM32UVBIF)

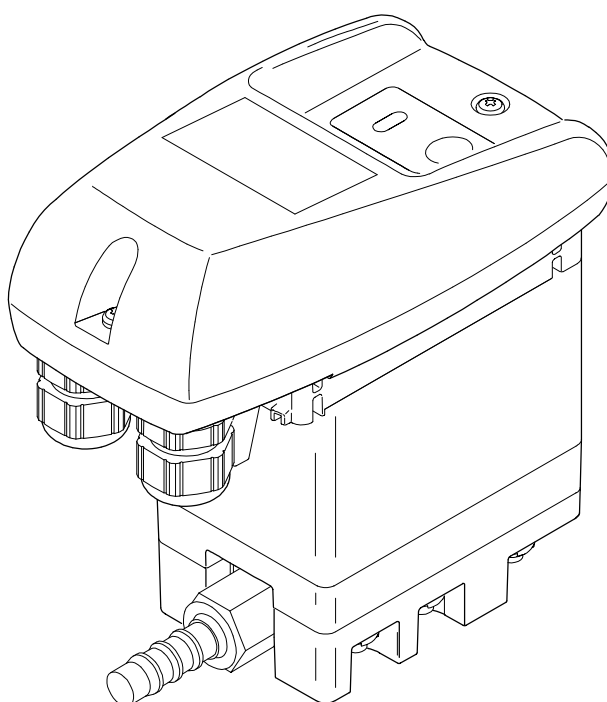

Dear customer,

Thank you for deciding in favor of the BEKOMAT® 32U Vario built-in F condensate drain. Please read the installation and operating instructions carefully before mounting and starting up the BEKOMAT® 32U Vario built-in F, and follow our directions. Perfect functioning of the BEKOMAT® 32U Vario built-in F, and thus reliable condensate discharge, can only be guaranteed when the provisions and notes stipulated here are strictly adhered to.

1	Pictograms and symbols	4
2	Safety instructions	4
3	Proper use	6
4	Exclusion from the scope of application	6
5	Technical data	7
6	Electrical data	8
7	Dimension drawing	9
8	Function	10
9	Installation	13
10	Electrical installation	16
11	Control and maintenance	19
12	Troubleshooting and fault elimination	23
13	Elements and components	24
14	Recommended spare parts	25
15	Accessories	25
16	Declaration of conformity	26

1 Pictograms and symbols



Observe the installation and operating instructions



Observe the installation and operating instructions
(on the type plate)



General danger symbol (danger, warning, caution)



General danger symbol (danger, warning, caution) for supply voltage and supply voltage-carrying plants components

2 Safety instructions



Please check whether or not these instructions correspond to the device type.

Adhere to all advice given in these operating instructions. They include essential information which must be observed during the installation, operation and maintenance. Therefore it is imperative for the service technician and the responsible operator / technical staff to read these operating instructions prior to installation, start-up and maintenance.

The operating instructions must be accessible at any time at the place of application of the BEKOMAT® 32U Vario built-in.

In addition to these operating instructions, local or national regulations must be complied with, if necessary.

Make sure that the BEKOMAT® 32U Vario built-in is operated only within the permissible limit values indicated on the type plate. Any deviation involves a risk for persons and materials, and may result in malfunction and service failures.

If you have any queries regarding these installation- and operating instructions, please contact BEKO TECHNOLOGIES CORP.



Danger!

Compressed air!

Risk of serious injury or death through contact with quickly or suddenly escaping compressed air or through bursting plant components or plant components which are not secured.

Measures:

- Do not exceed the maximum operating pressure (see type plate).
- **Only carry out service measures when the system is pressure less.**
- Use pressure-resistant installation material only.
- The feed pipe must be tubed firmly. Discharge pipe: short, fixed pressure hose onto pressure-resistant pipe.
- Make sure that persons or objects cannot be hit by condensate or escaping compressed air.



Danger!

Supply voltage!

There is the risk of an electric shock involving injury or death when coming into contact with non-insulated components carrying supply voltage.

Measures:

- During electric installations, all regulations in force need to be adhered to (e.g. VDE 0100 / IEC 60364).
- **When the control unit is open, service and installation works must only be undertaken when the system is deactivated.**
- **The removed control unit has no IP degree of protection.**
- All types of electrical works must be carried out by authorized and qualified personnel only.

Further safety instructions:

- For installation and operation, the national regulations and safety codes in force must also be adhered to.
- Do not use the BEKOMAT® 32U Vario built-in in hazardous areas.
- Regarding the inlet screw joints, excessive tightening forces must be avoided. This applies in particular to conical screw joints.
- The BEKOMAT® 32U Vario built-in will only function when voltage is applied.
- Do not use the test button for permanent drainage.
- Use genuine spare parts only. This is imperative to ensure perfect functioning.

Additional advice:

- The removed control unit has **no IP degree of protection**.
- During installation, use spanner flat at the feed pipe (wrench size SW27) as a back rest.
- The service unit must not be dismantled.



Caution!

Malfunction during operation!

Through incorrect installation and poor maintenance, malfunction may occur at the BEKOMAT.

Condensate which is not discharged may cause damage to plants and in production processes.

Measures:

- Condensate drainage which is reliable in performance directly optimizes the compressed-air quality.
- To prevent damage and breakdowns, it is imperative to observe the following:
 - Exact compliance with the specifications of use and with the performance parameters of the BEKOMAT, in connection with the case of application (see "Proper use" section)
 - Exact compliance with the installation- and operation instructions in this manual
 - Regular maintenance and control of the BEKOMAT in accordance with the instructions in this operating manual



3 Proper use

- The BEKOMAT® 32U Vario built-in F is an electronically level-controlled condensate drain for compressed-air plants.
- The device is employed within the permissible performance parameters (see "Technical data").
- The BEKOMAT® 32U Vario built-in F is able to drain condensate under operating pressure from the plant components virtually without compressed-air loss.
- For its function, the BEKOMAT® 32U Vario built-in F requires a supply voltage and an operating pressure (see "Technical data").
- As far as the employment in plants with increased demands on compressed air is concerned (food industry, medical technology, laboratory equipment, special processes etc.), the operator must decide on measures for the monitoring of the compressed-air quality. These have an effect on the safety of the subsequent processes and may prevent damage to persons and plants.
- It is the task of the operator to ensure that the indicated conditions are met during the entire operating time.
- The BEKOMAT Vario is a condensate drain whose properties are adjusted especially to prescribed applications.
- BEKOMAT Vario devices must not be employed at drain points other than those prescribed by the supplier, as this may result in malfunction and damage in the compressed-air system and at the compressed-air consumers.
- BEKOMAT Vario devices must not be replaced by other BEKOMAT-types, as this may result in malfunction and damage in the compressed-air system and at the compressed-air consumers.

4 Exclusion from the scope of application

- The BEKOMAT® 32U Vario built-in F as a condensate drain **alone cannot** guarantee a defined compressed-air quality, for this purpose, other additional technical devices are required.
- BEKOMAT® 32U Vario built-in F is **not** suitable for use in plants carrying vacuum or atmospheric ambient pressure or in ex-areas.
- The BEKOMAT® 32U Vario built-in F must not be exposed to permanent direct solar or thermal radiation.
- The BEKOMAT® 32U Vario built-in F must not be installed and operated in areas with an aggressive atmosphere.
- The BEKOMAT® 32U Vario built-in F is not heatable and, therefore, not suitable for the use in areas where frost is likely to occur.
- The BEKOMAT® 32U Vario built-in F is not suitable for CO₂ plants.

5 Technical data

  	
min./max. operating pressure (see type plate)	0,8...16 bar (12...230 psi) or 1,2...16 bar (17...230 psi)
min./max. temperature (see type plate)	+1...+60 °C (+34...+140 °F) or +1...+70 °C (+34...+158 °F)
Condensate inflow	NPT ½ (G ½) internal max. screw-in depth 13,5 mm (½")
Condensate outflow	G ¼ Ø 8 ... 10 mm hose connector
Condensate	oil-contaminated + oil-free
Housing	aluminium + plastic, glass fibre-reinforced
Weight (empty)	0,8 kg (1.8 lbs)

This product has been tested to the requirements of CAN/CSA-C22.2 No. 61010-1-12, third edition, including a later version of the same standard incorporating the same level of testing requirements.

Electrical data

6 Electrical data

Supply voltage (see type plate)	95...240 VAC $\pm 10\%$ (50...60 Hz) / 100...125 VDC $\pm 10\%$ or 24...48 VAC $\pm 10\%$ (50...60 Hz) / 18...72 VDC $\pm 10\%$
Power consumption	P = 0,6 ... 3 VA (W)
Recommended cable-jacket diameter	\varnothing 5,0...10 mm (0,20"...0,39")
Recommended wire cross section Spring-loaded terminal (voltage supply/relay)	0,75...1,5 mm ² (AWG 16...20)
Recommended wire cross section Screw terminal (voltage supply)	0,75...2,5 mm ² (AWG 14...20)
Recommended wire cross section Spring-loaded terminal (external test)	0,75...1,5 mm ² (AWG 16...20)
Recommended wire cross section Screw terminal (relay/external test)	0,75...1,5 mm ² (AWG 16...20)
Recommended stripping of cable jacket (voltage supply/relay)	~ 30 mm (~ 1.18")
Recommended stripping of cable jacket (external test)	~ 90 mm (~ 3.54")
Recommended length of the wire end tube Spring-loaded terminal	8 mm (~ 0.31 inch)
Recommended length of the wire end tube Screw terminal	~ 6 mm (~ 0.24 inch)
Connection data of the potential- free contact Switch to load*)	AC: max. 250V / 1A DC: max. 30V / 1A
Connection data of the potential-free contact Switch to low signal*)	min. 5 VDC / 10 mA
Connection data of the external test contact	on the unit side 5 VDC; switching current $\geq 0,5$ mA
Protection class	IP 67
Overvoltage category (IEC 61010-1)	II

VAC = V alternating current

VDC = V direct current

*) The switching of loads means that the properties of the contact are no longer suitable for the switching of low signals.

7 Dimension drawing

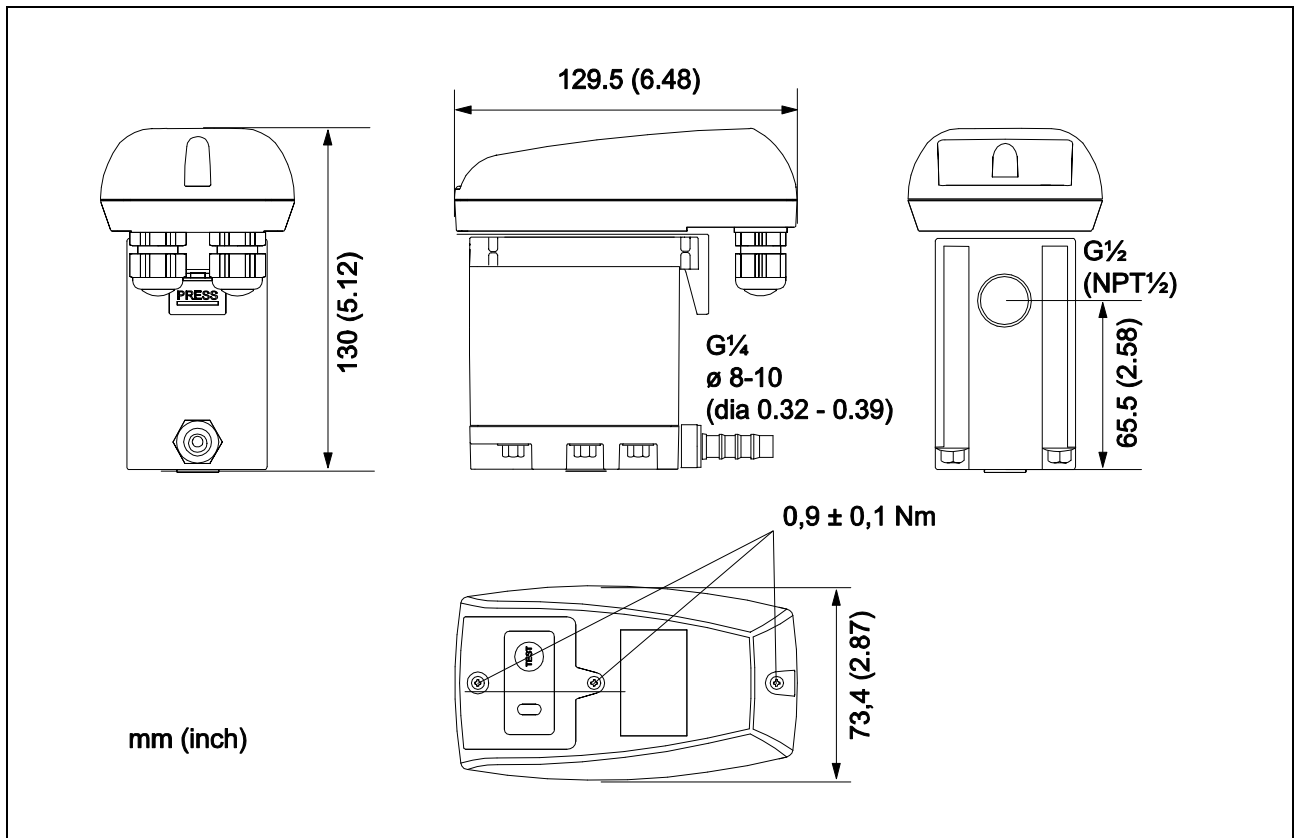

8 Function

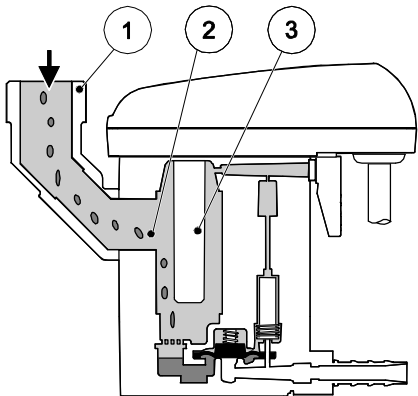

Via the inlet line (1), the condensate flows into the BEKOMAT® 32U Vario built-in and accumulates in the housing (2).
A capacitive functioning sensor (3) continuously registers the filling level.

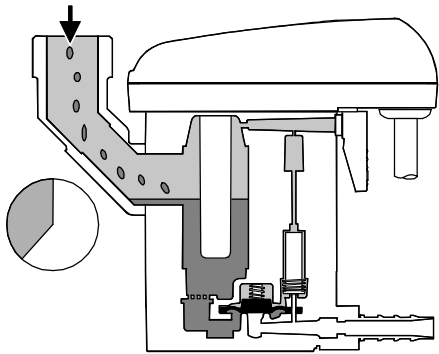

As soon as the condensate has reached a certain level, a fixed waiting time starts.
During this period, further condensate flows in and continues filling the BEKOMAT.
BEKOMAT and upstream units must be adjusted to each other.

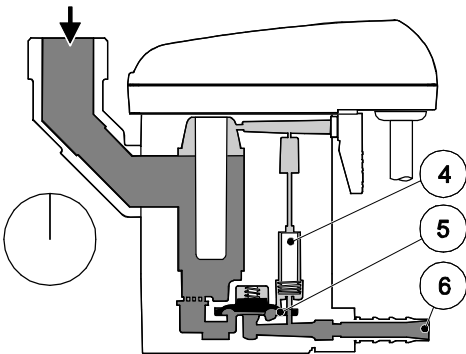

After the waiting time has expired, the condensate may have risen up to the inlet area (1). The solenoid valve (4) is switched over now and the zone above the valve membrane is vented.
The valve membrane (5) lifts off from the valve seat, the overpressure in the housing forces the condensate into the outlet line (6).
The total amount of accumulated condensate is discharged.

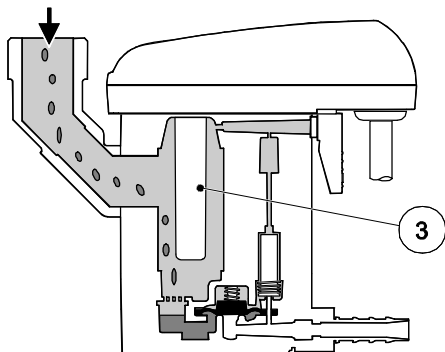

When the sensor (3) is "free", meaning that the total amount is discharged, the solenoid valve re-switches and the valve membrane is re-closed tightly through the overpressure which builds up above the latter membrane.
A new cycle starts with the inflow of condensate (1).

At the BEKOMAT® 32U Vario built-in, two LEDs indicate the individual operating states.

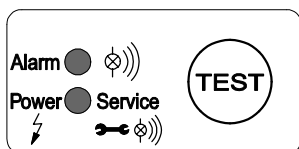

When applying supply voltage, the BEKOMAT® 32U Vario built-in carries out a **self-test**. Both LEDs are lit for approximately 1 second, subsequently, the device changes over to the "ready-to-operate" state.

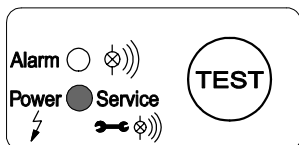

Ready to operate, voltage is applied.

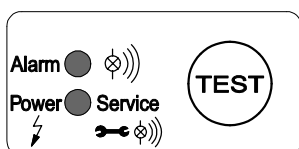

In the event that the condensate discharge is disturbed, an alarm mode will start which is indicated by the flashing of the red alarm LED.

Malfunction/alarm

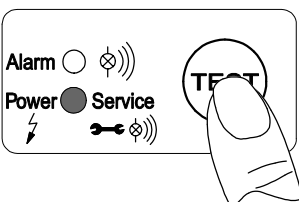

Test of the valve function (manual drainage): press and hold the button for approximately 2 s.
Test of the alarm function (see below): press and hold the button for at least 1 min.

Do not use for permanent drainage.

Switching sequence of the valve in the alarm mode

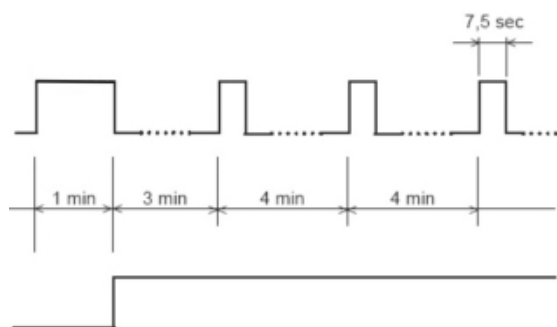

Trouble indication via a potential-free contact

Alarm mode:

In the event that the BEKOMAT is not empty after one minute, a trouble indication is released:

- The alarm LED flashes.
- The alarm relay switches over (the signal can be picked off potential-freely).
- The valve opens every four minutes for 7.5 seconds.
- When the malfunction has been eliminated, the BEKOMAT will switch back automatically into the normal mode.

Possible trouble sources include :

- Mistakes during installation
- Dropping below the minimum pressure
- Excessive accumulation of condensate (excess load)
- Blocked / obstructed outlet line
- Extreme amount of dirt particles
- Frozen pipe work

The BEKOMAT® 32U Vario built-in F releases a maintenance message for a service that is to be carried out.

Depending on the operating mode, a visual maintenance message (service) is activated which signals the replacement of the service unit.

The maintenance message is indicated by the flashing supply voltage-LED "Power".

The maintenance message is released after 1 x 8.760 h or one million switching cycles.

The maintenance signal is released when one of these two values is reached.

In the event of a power outage or when the energy supply is deactivated, the status of the timer will be maintained.

The activities to be carried out regarding maintenance are described in the chapter entitled "Check and maintenance".

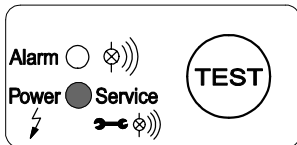

Prior to the replacement of the service unit, a reset needs to be carried out. The control unit is released by actuating the arresting hook. When removed, the TEST button must be pressed and held for at least five seconds.

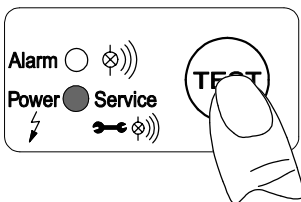

9 Installation

**Danger!****Compressed air!**

Risk of serious injury or death through contact with quickly or suddenly escaping compressed air or through bursting plant components or plant components which are not secured.

Measures:

- Do not exceed the maximum operating pressure (see type plate).
- **Only carry out service measures when the system is pressure less.**
- Use pressure-resistant installation material only.
- The feed pipe must be tubed firmly. Discharge pipe: short, fixed pressure hose onto pressure-resistant pipe.
- Make sure that persons or objects cannot be hit by condensate or escaping compressed air.

**Caution!****Malfunction during operation!**

Through incorrect installation and poor maintenance, malfunction may occur at the BEKOMAT.

Condensate which is not discharged may cause damage to plants and in production processes.

Measures:

- Condensate drainage which is reliable in performance directly optimizes the compressed-air quality.
- To prevent damage and breakdowns, it is imperative to observe the following:
 - Exact compliance with the specifications of use and with the performance parameters of the BEKOMAT, in connection with the case of application (see "Proper use" section)
 - Exact compliance with the installation- and operation instructions in this manual
 - Regular maintenance and control of the BEKOMAT in accordance with the instructions in this operating manual

Installation



Note

It is imperative to observe all hazard statements and warnings listed here.

Please also observe all regulations and notes regarding industrial safety and fire prevention at the place of installation.

As a matter of principle, only use suitable and appropriate tools and materials in a proper condition.

Do not use aggressive cleaners and improper devices such as high-pressure cleaners.







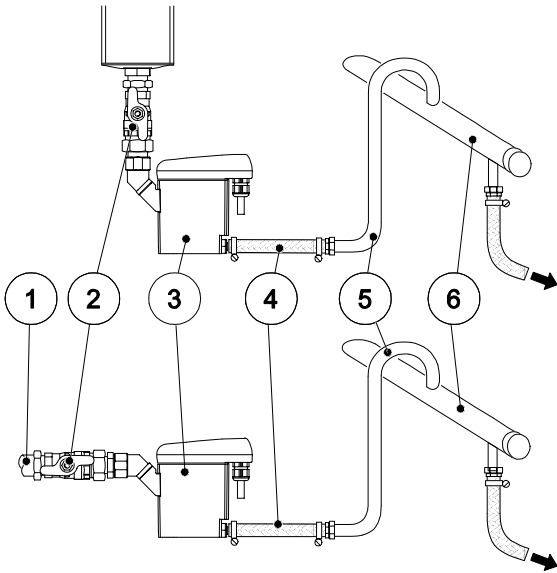

Please note that condensates may contain aggressive or harmful components. Therefore, skin contact should be avoided.

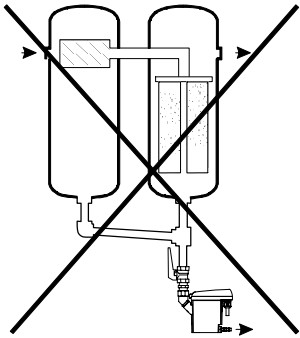
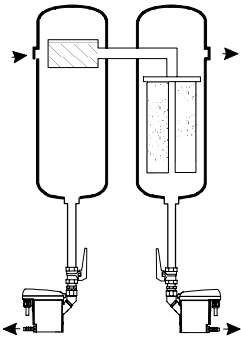
Condensate is subject to mandatory waste disposal. As such, it must be collected in suitable containers, and disposed of or processed properly.

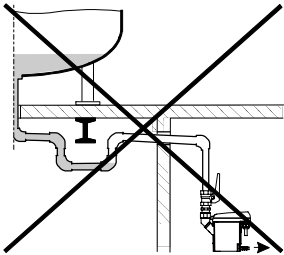
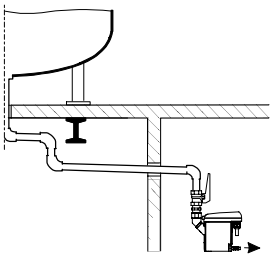
Installation instructions:

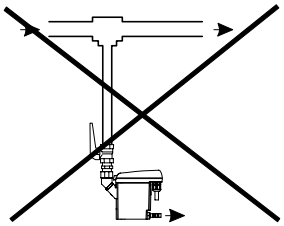
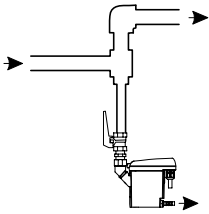

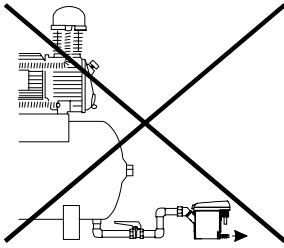
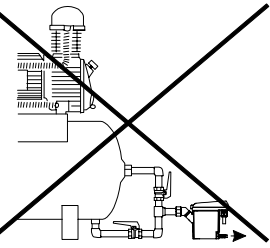
- Only the displayed installation position of the BEKOMAT (3) is permissible. Never install in a horizontal or any other tilted position.
- Feed pipe (1) and ball valve (2) at least G $\frac{1}{2}$.
- No filter or screen in the inlet line.
- Slope in the inlet line >1%.
- Use ball valves (2) only.
- Operating pressure: min. 0,8/1,2 bar (12/17 psig), max. 16 bar (230 psig). See type plate.
- Short pressure hose (4) fixed on a pressure-resistant pipe.
- The required minimum pressure increases by 0,1 bar (1,4 psi) per metre gradient in the discharge pipe (5).
- Discharge pipe (5) rising by max. 5 m (16,4ft).
- Install manifold (6) $\frac{3}{4}$ " with a slope of 1%.
- Introduce the discharge pipe (5) from the top into the manifold (6).
- Prior to the start-up, always carry out a leak test and verify the correct engagement of the control unit.

wrong	correct	
		<p> Pressure differences!</p> <p>Each condensate accumulation point must be drained separately.</p>
		<p> Continuous slope!</p> <p>Avoid a water pocket when installing the feed pipe</p>
		<p> Deflector area!</p> <p>If drainage is to be carried out directly from the pipe, deflection of the air flow will be useful.</p>
		<p> No venting line!</p> <p>Do not install a venting line for a BEKOMAT® 32U Vario built-in! Installations, where a venting line is normally required, are impossible in this case. Another suitable BEKOMAT must be used.</p>

10 Electrical installation



Danger!

Supply voltage!

There is the risk of an electric shock involving injury or death when coming into contact with non-insulated components carrying supply voltage.

Measures:

- During electric installations, all regulations in force need to be adhered to (e.g. VDE 0100 / IEC 60364).
- **When the control unit is open, service and installation works must only be undertaken when the system is deactivated.**
- **The removed control unit has no IP degree of protection.**
- All types of electrical works must be carried out by authorized and qualified personnel only.

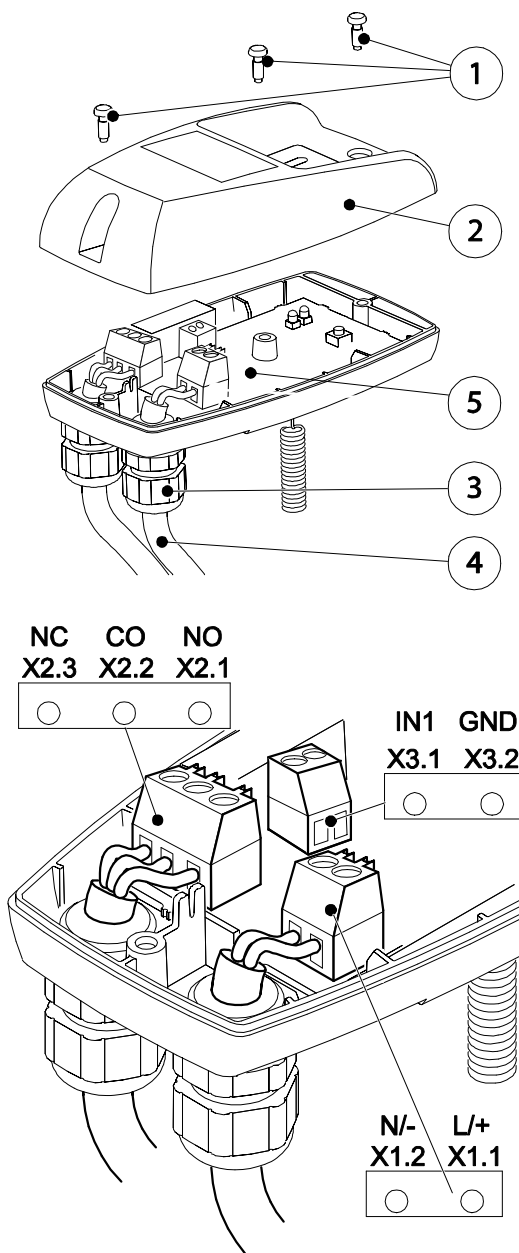

Note:

Power supply connection:

1. Read the permissible supply voltage on the type plate and make sure this voltage is observed.
2. For the supply voltage, a reliably accessible separator must be provided close-by (e.g. power plug or switch), which separates all current-carrying conductors.
3. At a low voltage supply (< 50 VAC / < 75 VDC), only use a protective extra-low-voltage.
4. Carry out installation in accordance with VDE 0100 / IEC 60364.
5. Observe the terminal assignment.
6. Do not install when the device is energized.
7. Unscrew the screws (1) and remove the upper part of the cover (2).
8. Unscrew the threaded cable connection (3), remove the plug (if there is one), and lead the cable (4) for the power supply through.
9. Connect the cable (4) with terminals X1 (1.1, 1.2) (5).
10. Install the cables as shown (see also terminal assignment in the following text).
11. Tighten the threaded cable connection (3) with a slightly sealing effect.
12. Put on the upper part of the cover (2) and tighten the screws (1) fingertight.

Connection of the potential-free contact and of the external test:

1. Selection of the suitable cable.
2. Connection to X2 and X3, as shown on the left.
3. The installation steps are the same as for the power supply connection.
4. If the potential-free contact carries voltage that is dangerous in the case of contact, a corresponding separator must also be provided, as described above.
5. When using the potential-free contacts and the connection external test, sufficient clearance to the other parts of the unit, or suitable insulation in accordance with EN 60664-1 must be ensured.
6. When using a multiwire, common line for the connection of the potential-free contact and the external test, this line must be suitable for the highest occurring voltage and the intended temperature range with regard to its nominal ratings.

Terminal assignment supply voltage (operating voltage)

X 1		X 2			X 3	
L/+	N/-	NO	CO	NC	IN1	GND
phase	neutral	normally open	common	normally closed	external test (IN1)	GND
1.1	1.2	2.1	2.2	2.3	3.1	3.2

Power supply

- X 1.1 L/+
- X 1.2 N/-

L = Outer conductor

N = Neutral conductor

Terminal assignment low voltage (operating voltage)

X 1		X 2			X 3	
L/+	N/-	NO	CO	NC	IN1	GND
power	power	normally open	common	normally closed	external test (IN1)	GND
1.1	1.2	2.1	2.2	2.3	3.1	3.2

Power supply

- X 1.1 L/+
- X 1.2 N/-

Electrical installation

Terminal assignment of the potential-free contact and of the external test

X 1		X 2			X 3	
L/+	N/-	NO	CO	NC	IN1	GND
power	power	normally open	common	normally closed	external test (IN1)	GND
1.1	1.2	2.1	2.2	2.3	3.1	3.2



Fault indication/potential-free contact:

- X 2.1 n.o.
- X 2.2 com.
- X 2.3 n.c.

n.c. - com. closed in the event of malfunction or power failure (closed current principle)

n.o. - com. closed during normal operation

The contacts X2.1 - 2.3 are potential-free.

External test / remote control:

- X 3.1 external test (IN1)
- X 3.2 GND

Contacts connected = test active = discharge

Contacts open = test inactive

The contacts X 3.1 -3.2 are not potential-free.



Note:

At a low-voltage supply (< 50 VAC / < 75 VDC), only use a protective extra-low-voltage.
Tighten the threaded cable connection with a slightly sealing effect.

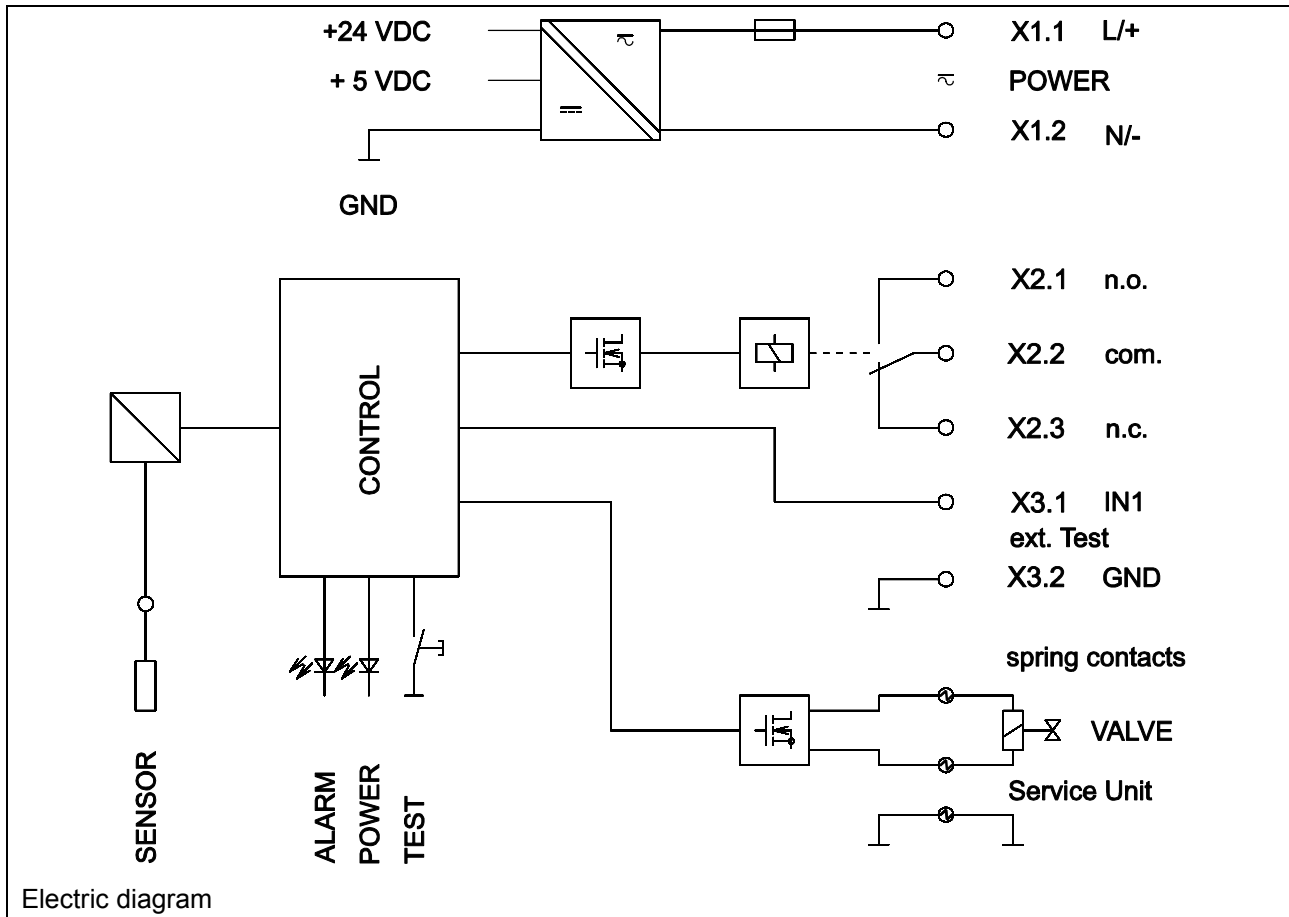

Electric diagram

11 Control and maintenance



Danger!

Compressed air!

Risk of serious injury or death through contact with quickly or suddenly escaping compressed air or through bursting plant components or plant components which are not secured.

Measures:

- Do not exceed the maximum operating pressure (see type plate).
- **Only carry out service measures when the system is pressure less.**
- Use pressure-resistant installation material only.
- The feed pipe must be tubed firmly. Discharge pipe: short, fixed pressure hose onto pressure-resistant pipe.
- Make sure that persons or objects cannot be hit by condensate or escaping compressed air.



Danger!

Supply voltage!

There is the risk of an electric shock involving injury or death when coming into contact with non-insulated components carrying supply voltage.

Measures:

- During electric installations, all regulations in force need to be adhered to (e.g. VDE 0100 / IEC 60364).
- **When the control unit is open, service and installation works must only be undertaken when the system is deactivated.**
- **The removed control unit has no IP degree of protection.**
- All types of electrical works must be carried out by authorized and qualified personnel only.



Caution!

Malfunction during operation!

Through incorrect installation and poor maintenance, malfunction may occur at the BEKOMAT.

Condensate which is not discharged may cause damage to plants and in production processes.

Measures:

- Condensate drainage which is reliable in performance directly optimizes the compressed-air quality.
- To prevent damage and breakdowns, it is imperative to observe the following:
 - Exact compliance with the specifications of use and with the performance parameters of the BEKOMAT, in connection with the case of application (see "Proper use" section)
 - Exact compliance with the installation- and operation instructions in this manual
 - Regular maintenance and control of the BEKOMAT in accordance with the instructions in this operating manual



Note

It is imperative to observe all hazard statements and warnings listed here.

Please also observe all regulations and notes regarding industrial safety and fire prevention at the place of installation.

As a matter of principle, only use suitable and appropriate tools and materials in a proper condition.

Do not use aggressive cleaners and improper devices such as high-pressure cleaners.

Please note that condensates may contain aggressive or harmful components. Therefore, skin contact should be avoided.

Condensate is subject to mandatory waste disposal. As such, it must be collected in suitable containers, and disposed of or processed properly.

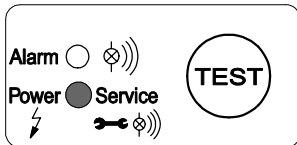

Maintenance recommendation:

After 8,760 operating hours or one million switching cycles, a maintenance message is released.

The green power LED flashes. Afterwards, or at the latest after one year (8,760 operating hours), the service unit (5) needs to be replaced.

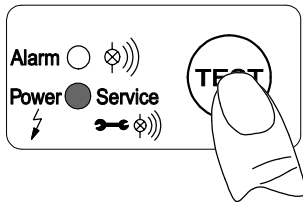

1. Prior to the replacement of the service unit, a reset needs to be carried out. The control unit is released by actuating the arresting hook. When removed, the TEST button below the LED must be pressed and held for at least five seconds.

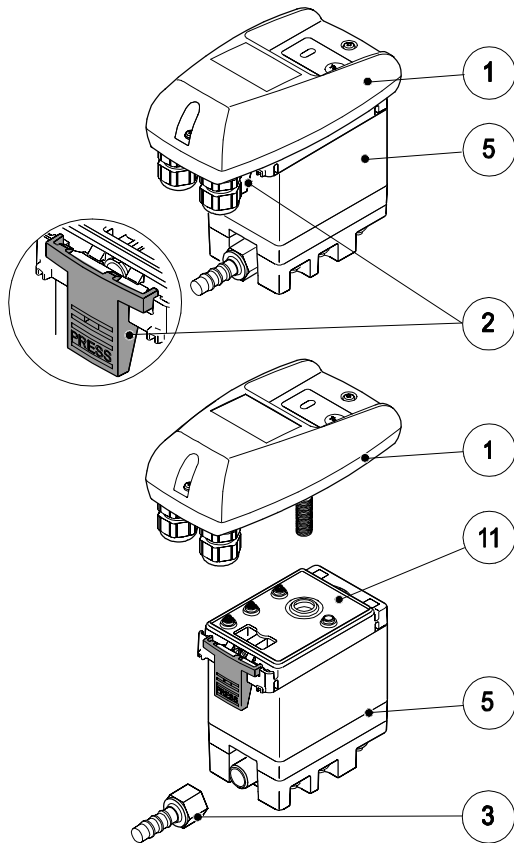

2. Remove the control unit (1) by pressing the arresting hook (2).
3. Unfasten the BEKOMAT® 32U Vario built-in from the outlet (3).
4. Detach the service unit (5) from the tubing at the inlet by removing the union nut.

5. Check whether or not the new service unit (5) goes with the control unit (1) (model designation and color of the arresting hook (2)).
6. Installation of the new service unit (5) in reverse order.

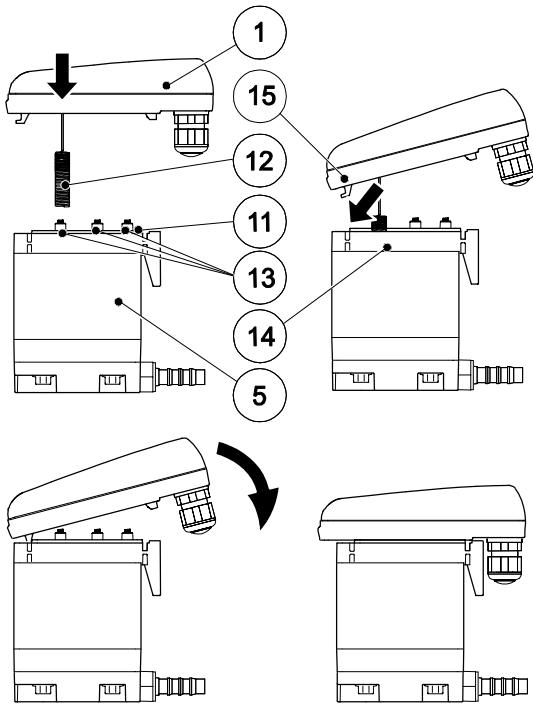

Installation of the control unit on the service unit:

1. Check whether or not the service unit (5) goes with the control unit (1) (model designation and color of the arresting hook).
2. Check whether or not the sealing mat (11) and the contact springs (13) are clean, dry, and free from impurities.
3. Introduce the sensor (12) into the sensor tube plate (14).
4. Hang the hook (15) of the control unit (1) in the sensor tube plate (14).
5. Press the control unit (1) against the service unit (5) and snap into place.

Start subsequent to maintenance measures:

Always carry out prior to the start-up:

- Leak test of the screwed connector
- Check of the electrical connections
- Check of the correct engagement of the control unit

12 Troubleshooting and fault elimination

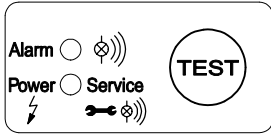
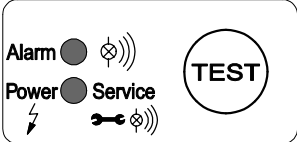
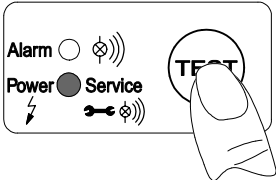
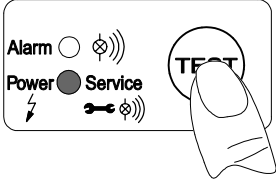
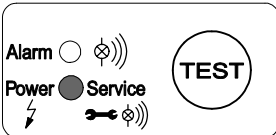
Symptoms	Possible reasons	Measures
 <p>No LED lights up</p>	<p>Supply voltage incorrect Circuit board defective</p>	<p>Check the voltage on the type plate Check the connections and the supply voltage Check the circuit boards for possible damage</p>
 <p>All LEDs are continuously on</p>	<p>Failure during the start of the program Circuit board defective</p>	<p>Separate the device from the supply voltage and reactivate after > 5 s Check the circuit boards for possible damage</p>
 <p>Test button pressed, but no condensate discharge</p>	<p>Feed pipe and/or discharge pipe blocked or obstructed Wear and tear Circuit board defective Service unit defective Minimum pressure not reached Maximum pressure exceeded</p>	<p>Check feed and discharge pipe Check whether or not the valve opens audibly (press the test button several times for >2 seconds) Check the circuit board for possible damage Check the operating pressure</p>
 <p>Condensate discharge only when the test button is pressed</p>	<p>Feed pipe without sufficient slope Cross section not large enough Condensate accumulation too high (surge) Service unit extremely dirty</p>	<p>Install feed pipe with a slope Replace the service unit</p>
 <p>Device blows off continuously</p>	<p>Service unit defective or dirty</p>	<p>Replace the service unit</p>

13 Elements and components

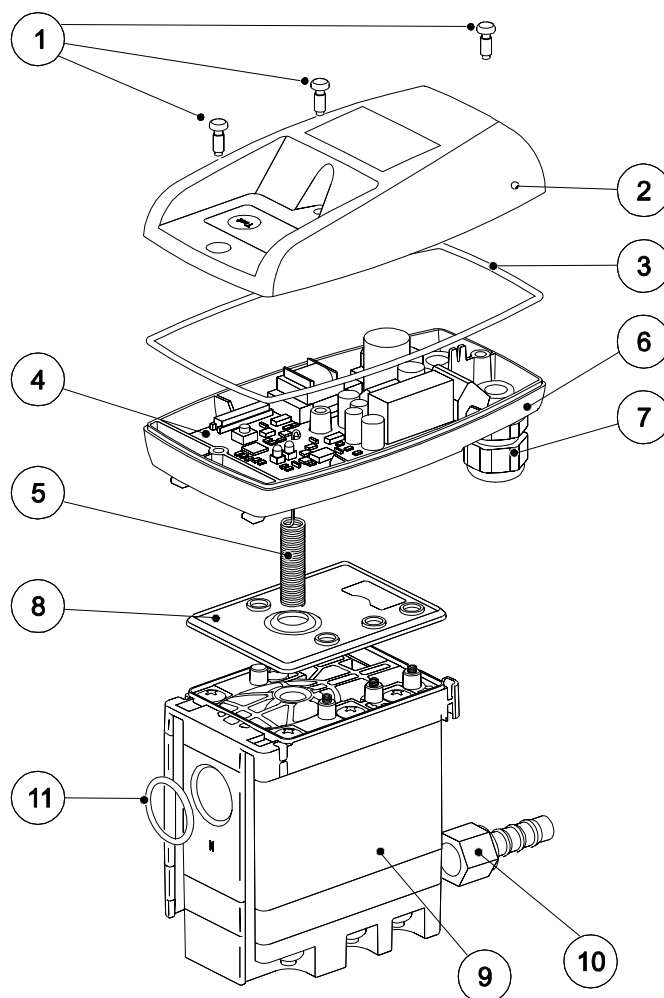

- 1 Screw 3.5 x 10
- 2 Upper part of the cover
- 3 Moulded gasket
- 4 Circuit board
- 5 Sensor
- 6 Lower part of the cover

- 7 Cable bushing
- 8 Sealing mat
- 9 Service unit
- 10 Hose connector
- 11 O-ring 20 x 2

14 Recommended spare parts

Available sets of spare parts	Contents	Order number
Service unit Vario F	8, 9, 11*	4023575
Gasket kit	3, 8, 11*	4024392
Design shell*	16*	4010167
Connection adapter G*	11*, 12*, 13*, 14*, 15*	4010155
Connection adapter NPT*		4012610

* Not for BEKOMAT 32U Vario built-in F

15 Accessories

Available accessory sets	Contents	Order number
Outlet set With a hose and installation material	Tubing piece 10x3x800 Grommet 9-G½ Ms Hose clamp 12-22/9 A2	2000045

16 Declaration of conformity

BEKO TECHNOLOGIES GMBH
41468 Neuss, GERMANY
Tel: +49 2131 988-0
www.beko-technologies.com



EG-Konformitätserklärung

Wir erklären hiermit, dass die nachfolgend bezeichneten Produkte den Anforderungen der einschlägigen Richtlinien und technischen Normen entsprechen. Diese Erklärung bezieht sich nur auf die Produkte in dem Zustand, in dem sie von uns in Verkehr gebracht wurden. Nicht vom Hersteller angebrachte Teile und/oder nachträglich vorgenommene Eingriffe bleiben unberücksichtigt.

Produktbezeichnung:	Kondensatableiter
Modelle:	BEKOMAT 31U, 32U, 32UV, 33U, 33UV
Spannungsvarianten:	95...240 VAC $\pm 10\%$ (50...60 Hz) / 100...125 VDC $\pm 10\%$ oder 24...48 VAC $\pm 10\%$ (50...60 Hz) / 18...72 VDC $\pm 10\%$
Betriebsdruckbereich:	0,8...16 bar (12...230 psi) oder 1,2...16 bar (17...230psi)
Produktbeschreibung und Funktion:	Kondensatableiter zur elektronisch niveaugeregelten Ableitung von Kondensat im Druckluftnetz.

Niederspannungs-Richtlinie 2006/95/EG

Angewandte harmonisierte Normen: EN 61010-1:2010
Anbringungsjahr der CE-Kennzeichnung: 13

Die Geräte mit einer Betriebsspannung von 24...48 VAC und 18...72 VDC fallen nicht in den Anwendungsbereich der Niederspannungs-Richtlinie.

EMV-Richtlinie 2004/108/EG

Angewandte harmonisierte Normen: EN 61326-1:2006
EN 55011:2009 + A1: 2010, Gruppe 1, Klasse B

RoHS Richtlinie 2011/65/EU

Die Vorschriften der Richtlinie 2011/65/EU zur Beschränkung der Verwendung bestimmter gefährlicher Stoffe in Elektro- und Elektronikgeräten werden erfüllt.

Neuss, 21.08.2013

BEKO TECHNOLOGIES GMBH

A handwritten signature in black ink, appearing to read "Christian Riedel".

i.V. Christian Riedel
Leiter Qualitätsmanagement

BEKO TECHNOLOGIES GMBH
41468 Neuss, GERMANY
Tel.: +49 2131 988 0
www.beko-technologies.com



EC Declaration of Conformity

We hereby declare that the products indicated hereafter comply with the stipulations of the relevant directives and technical standards. This declaration only refers to products in the condition in which they have been placed into circulation. Parts which have not been installed by the manufacturer and/or modifications which have been implemented subsequently remain unconsidered.

Product designation:	Condensate drain
Types:	BEKOMAT 31U, 32U, 32UV, 33U, 33UV
Voltage options:	95...240 VAC $\pm 10\%$ (50...60 Hz) / 100...125 VDC $\pm 10\%$ or 24...48 VAC $\pm 10\%$ (50...60 Hz) / 18...72 VDC $\pm 10\%$
Operating pressure range:	0.8...16 bar (12...230 psi) or 1.2...16 bar (17...230psi)
Product description and function:	Condensate drain for the electronically level-controlled discharge of condensate in the compressed-air system.

Low-Voltage Directive 2006/95/EC

Harmonized standards applied:	EN 61010-1:2010
Year of CE labeling:	13

The devices with a supply voltage of 24...48 VAC and 18...72 VDC do not come under the scope of the Low-Voltage Directive.

EMC Directive 2004/108/EC

Harmonized standards applied:	EN 61326-1:2006 EN 55011:2009 + A1: 2010, group 1, class B
-------------------------------	---

RoHS Directive 2011/65/EU

The stipulations of the 2011/65/EU Directive on the restriction of the use of certain hazardous substances in electrical and electronic equipment are observed.

Neuss, 21 August 2013

BEKO TECHNOLOGIES GMBH

p.p. Christian Riedel
Head of Quality Department

A

Accessories 25
Accessory sets 25
Air compensation line 15
Alarm mode 11

B

blows off 23
Both LEDs are continuously on 23

C

Circuit board 24
Components 24
Condensate discharge disturbed 23
Control 19
Control unit 21

D

Danger compressed air 4, 13, 19
Danger supply voltage 5, 16, 19
Data 7
Declaration of conformity 26
Deflector area 15
Degree of protection 5, 16, 19
Dimension drawing 9
Dimensions 9

E

Electric diagram 18
Electrical data 8
Electrical data 8
Electrical installation 16
Elements 24
Exclusion from the scope of application 6
Exclusion of a field of application 6

F

Failure 23
Fault clearance 23
Fault diagnosis 23
Fault elimination 23
Field of application 6
Filling level 10
Function 10

H

Hose connector 24

I

Installation 13
Installation and operating instructions 4
Installations- und Betriebsanleitung 4

Instructions, safety instructions 4

L

Lower part of the cover 24

M

Maintenance 19
Maintenance recommendation 20
Malfunction 23
Mounting 13

N

No condensate discharge 23
No LED lights up 23

O

Order number 25

P

Piktogramme 4
Pressure differences 15
Proper use 6

Q

Qualified personnel 5, 16, 19

R

Recommended spare parts 25

S

Safety instructions 4
Self-test 11
Sensor 24
Sensor tube plate 22
Service measures 4, 13, 19
Service unit 20, 24
Sets of spare parts 25
Slope 15
Spare parts 5, 25
Symbole 4

T

Technical data 7
Trouble sources 11
Troubleshooting 23

U

Upper part of the cover 24

V

Venting line 15

W

Water pocket 15

<p>Headquarter :</p> <p>Deutschland / Germany BEKO TECHNOLOGIES GMBH Im Taubental 7 D-41468 Neuss Tel. +49 2131 988 0 beko@beko-technologies.com</p>	<p>中华人民共和国 / China BEKO TECHNOLOGIES (Shanghai) Co. Ltd. Rm.606 Tomson Commercial Building 710 Dongfang Rd. Pudong Shanghai China P.C. 200122 Tel. +86 21 508 158 85 info.cn@beko-technologies.cn</p>	<p>France BEKO TECHNOLOGIES S.à.r.l. Zone Industrielle 1 rue des Frères Rémy F- 57200 Sarreguemines Tél. +33 387 283 800 info@beko-technologies.fr</p>
<p>India BEKO COMPRESSED AIR TECHNOLOGIES Pvt. Ltd. Plot No.43/1, CIEEP, Gandhi Nagar, Balanagar, Hyderabad - 500 037, INDIA Tel. +91 40 23080275 eric.purushotham@bekoindia.com</p>	<p>Italia / Italy BEKO TECHNOLOGIES S.r.l Via Peano 86/88 I - 10040 Leini (TO) Tel. +39 011 4500 576 info.it@beko-technologies.com</p>	<p>日本 / Japan BEKO TECHNOLOGIES K.K KEIHIN THINK 8 Floor 1-1 Minamiwatarida-machi Kawasaki-ku, Kawasaki-shi JP-210-0855 Tel. +81 44 328 76 01 info@beko-technologies.jp</p>
<p>Benelux BEKO TECHNOLOGIES B.V. Veenen 12 NL - 4703 RB Roosendaal Tel. +31 165 320 300 benelux@beko-technologies.com</p>	<p>Polska / Poland BEKO TECHNOLOGIES Sp. z o.o. ul. Chłapowskiego 47 PL-02-787 Warszawa Tel +48 22 855 30 95 info.pl@beko-technologies.pl</p>	<p>Scandinavia www.beko-technologies.com</p>
<p>España / Spain BEKO Tecnológica España S.L. Torruella i Urpina 37-42, nave 6 E-08758 Cervello Tel. +34 93 632 76 68 info.es@beko-technologies.es</p>	<p>South East Asia BEKO TECHNOLOGIES S.E.Asia (Thailand) Ltd. 75/323 Romklao Road Sansab, Minburi Bangkok 10510 Thailand Tel. +66 2-918-2477 info.th@beko-technologies.com</p>	<p>臺灣 / Taiwan BEKO TECHNOLOGIES Co.,Ltd 16F.-5, No.79, Sec. 1, Xintai 5th Rd., Xizhi Dist., New Taipei City 221, Taiwan (R.O.C.) Tel. +886 2 8698 3998 peter.huang@beko-technologies.tw</p>
<p>Česká Republika / Czech Republic BEKO TECHNOLOGIES s.r.o. Na Pankraci 1062/58 CZ - 140 00 Praha 4 Tel. +420 24 14 14 717 info@beko-technologies.cz</p>	<p>United Kingdom BEKO TECHNOLOGIES LTD. 2 & 3 West Court Buntsford Park Road Bromsgrove GB-Worcestershire B60 3DX Tel. +44 1527 575 778 info@beko-technologies.co.uk</p>	<p>USA BEKO TECHNOLOGIES CORP. 900 Great SW Parkway US - Atlanta, GA 30336 Tel. +1 404 924-6900 beko@bekousa.com</p>

Translation of the original manual/instructions.

Original instructions are in German

Subject to technical modifications without notice / errors accepted.

BM32U_V_built_in_F_uc_manual_en-us_2014_08.

Printed in Germany