



# DRYPOINT® ACC 46 - 110

## Instruction & Technical Manual

BEKO TECHNOLOGIES CORP. 900 Great SW Parkway, Atlanta, Georgia 30336, USA  
+1 (800) 235-6797 Phone +1 (404) 629-6666 Fax beko@bekousa.com www.bekousa.com

EN



The product to which this manual refers must not be supplied, installed, used, operated or serviced until the contents of the manual has been fully read and understood by all relevant personnel.

**Please complete the following information at the time of installation**

found on the rating label on the upper right hand side of dryer

---

Model Number

---

Serial Number

---

Inlet Pressure

---

Filtration present with Dryer

---

Inlet Flow of Dryer

---

Supply Voltage

---

When contacting the manufacturer regarding this product, please have the above stated information at hand to speed up your query.

# Contents

<b>1</b>	<b>Safety</b>	<b>5</b>
	Safety Guidelines	5
	Symbols	6
<b>2</b>	<b>General Description</b>	<b>7</b>
	Function of the Dryer	7
	Controller Options	7
	Package Contents	8
	Primary Components	9 - 10
<b>3</b>	<b>Technical Data</b>	<b>10</b>
	Environmental Conditions	10
	Dimensional Specifications	11
	Sizing	12
<b>4</b>	<b>Mechanical Installation</b>	<b>13</b>
	Orientation	15
	Configuration of the inlet /outlet ports	16
	Connecting the pre-filter to the dryer	17
	Connecting the post-filter to the dryer	17
	Configuring the purge orifice	18
<b>5</b>	<b>Electrical Installation</b>	<b>20</b>
	Controller power supply options	20
	Controller specifications	21
	How to wire a DIN connector	22
	Alarm connection details	23

<b>6</b>	<b>Operation</b>	<b>24</b>
	Background / Function of the Dryer	24
	Detailed operational description	24
	Start-up procedure	25
	Shut-down procedure	25
	Operational schematics	26 - 30
<b>7</b>	<b>Energy Management</b>	<b>31</b>
	Overview	31
	Developing a purge control strategy	31
	Using a manual switch for purge control	31
	Using a standard pressure switch for purge control	31
	Using an electronic pressure switch for purge control	33
	Using a hygrometer and process controller for purge control	34
	Making connections between a switching device and dryer EM contact	34
<b>8</b>	<b>Maintenance</b>	<b>36</b>
<b>9</b>	<b>Spares Information</b>	<b>37</b>
	Service kits	37 - 41
	Accessory kits	42
<b>10</b>	<b>Component Parts</b>	<b>43</b>
<b>11</b>	<b>Troubleshooting</b>	<b>46</b>
<b>12</b>	<b>Warranty</b>	<b>49</b>

# Safety

---

**The following safety guidelines must be strictly observed.**

---

- *Leave this manual at the place of installation of the product.*
- *It is essential that only the manufacturer or its appointed agents carry out maintenance and servicing work.*

Users, maintenance and servicing personnel must be familiar with:

- *Accident prevention regulations.*
- *Safety information (general and specific to the unit).*
- *Safety devices of the unit.*
- *Measures to be taken in case of an emergency.*
- *Allow only suitably trained persons to be involved with installation, start-up, operation, servicing and maintenance of the product.*
- *It is the responsibility of the installer to ensure that the pipe work to and from the dryer is suitable, in accordance with applicable legislation and subject to inspection and testing prior to being put into service. All piping must be adequately supported.*
- *Before carrying out any maintenance or servicing work the unit must be taken out of operation. Users and others will be exposed to risk if work is carried out while the unit is running. This means electrical disconnection plus isolation from the compressed air supply and full depressurisation.*
- *Only trained and competent persons familiar with the electrical requirements of the unit as laid out in this manual and electrical safety rules and regulations should be allowed to carry out work on the electrical components and power supply to the unit.*
- *When carrying out any work on the unit, use only correctly sized appropriate tools in good condition.*
- *Only use original spare parts and accessories from the manufacturer. There is no guarantee that non-original parts have been designed and manufactured to meet the safety and operational requirements of the unit. The manufacturer assumes no liability for any equipment malfunction resulting from the use of non-approved parts.*
- *If carrying out installation work above head height, use suitable and safe working platforms or other means of working access.*
- *Do not make any constructional changes to the product. Any changes or modifications may only be carried out by the manufacturer.*
- *Any faults or defects that could affect safety must be put right fully before using the unit.*
- *Used items and materials must be disposed of in the correct manner, complying with local laws and regulations, in particular the desiccant cartridge.*

Figure 1.1: Definition of symbols

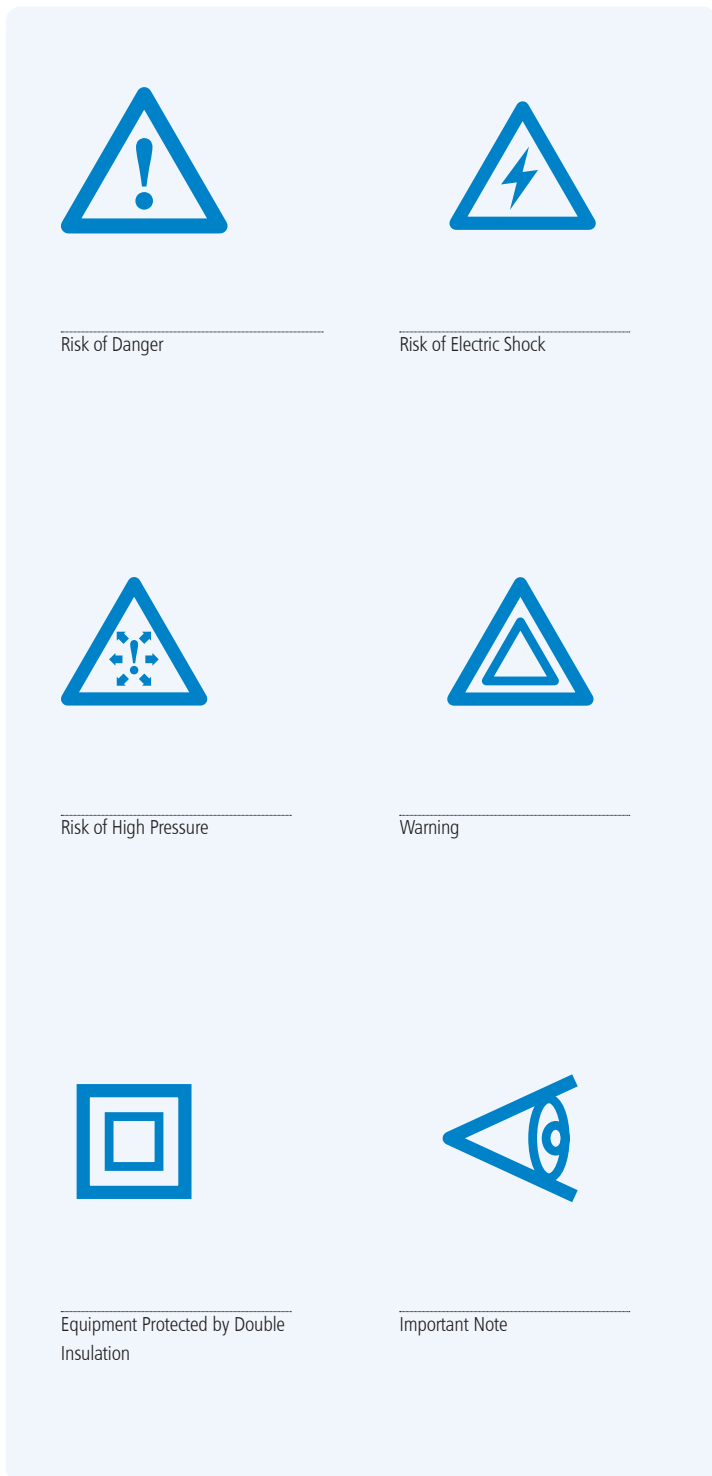

### Manual Handling

As with all areas of the workplace, Health and Safety is of great importance and must be given due care and attention. While working with this equipment, manual handling regulations must be considered and adhered to.

Full advice, support and guidance should be detailed in your Health and Safety Policy and Manual Handling guide, please take the time to familiarize yourself with these documents.

The Manual Handling Operations Regulations apply to a wide range of manual handling activities, including lifting, lowering, pushing, pulling or carrying.

We ask every person handling this product to take the responsibility for their own Health and Safety and the Health and Safety of others around them. If you feel there is a significant risk, you must take steps to either remove the risk altogether, or reduce the risk prior to carrying out the activity. If you need further support or guidance with this, please consult your line manager or the HR Department.

There are safe systems of work and correct procedures in relation to manual handling, please consult these documents available within the workplace.

We ask everyone handling this product to:

- Follow appropriate systems of work laid down for their safety.
- Make proper use of any equipment provided for their safety.
- Inform the company if they identify hazardous handling activities.
- Take care to ensure that their activities do not put others at risk.

If in doubt, please seek further advice and ensure you always follow the correct procedures and guidance.



For more information please see our Health and Safety manual attached.

A 3 amp fuse should be fitted as per the wiring diagram.

# General Description

## This manual is valid for the following dryer models

ACC 46  
ACC 56  
ACC 75  
ACC 90  
ACC 110

## Function of the Dryer

The dryer is designed to provide a smooth, controlled and uninterrupted delivery of dry compressed air. Wet air passes through a pre-filter and travels down to the bottom valve assembly. The air is then fed through the bottom of the desiccant bed and moves through the high performance desiccant until it becomes dry. On exit from the desiccant cartridge, the air is passed through the outlet valve assembly.

During this process, the dryer control system cycles the process air between the two desiccant towers. While one tower is on stream removing water vapor, the other is being carefully depressurized in preparation for regeneration. The desiccant bed is regenerated by expanding a small amount of dry process air, or purge air, through the saturated desiccant.

Purge air passes to atmosphere through the silencer, which is fitted to an exhaust valve. The tower is then repressurized, with the control system assuring each tower is at full operational pressure prior to changeover.

This ensures a reliable and efficient operation. The air stream is switched and the cycle repeats on a continuous basis.

Figure 2.1: Digital Display Controller

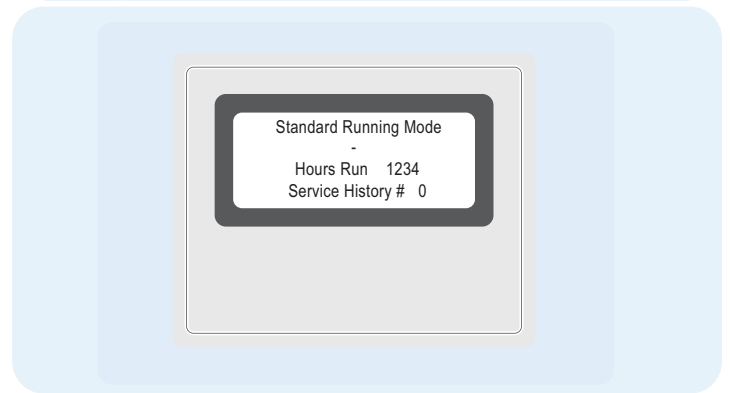

## Features:

- PLC based design.
- 115-240 VAC, 50-60 Hz or 24 VDC.
- Energy Management Feature (EM).
- Alarm Outputs.

## Desiccant Cartridge Options:

### Standard / Medical Cartridge:

- Standard default cartridge option.
- Non oxygen depleting.
- Capable of supporting outlet dewpoint levels of  $-4^{\circ}\text{F}$ ,  $-22^{\circ}\text{F}$  &  $-40^{\circ}\text{F}$  ( $-20^{\circ}\text{C}$ ,  $-30^{\circ}\text{C}$  &  $-40^{\circ}\text{C}$ ) with appropriate sizing per factors provided on page 12.

### High Performance Cartridge:

- Capable of supporting outlet dewpoint levels of  $-4^{\circ}\text{F}$ ,  $-22^{\circ}\text{F}$ ,  $-40^{\circ}\text{F}$ ,  $-94^{\circ}\text{F}$  &  $-100^{\circ}\text{F}$  ( $-20^{\circ}\text{C}$ ,  $-30^{\circ}\text{C}$ ,  $-40^{\circ}\text{C}$ ,  $-70^{\circ}\text{C}$  &  $-74^{\circ}\text{C}$ ) with appropriate sizing per factors provided on page 12.

## Section 2: General Description

### Package Contents

The dryer is delivered in protective packaging. Take care when transporting, loading and unloading the unit. The package contains the following items (refer to figure 2.2):

1. Dryer unit
2. Pre-filter and Post-filter, 0.01 micron, shipped loose
3. Instruction manual
4. Lifting Eyelet(s)
5. Purge Kit

Figure 2.2: Package contents (All dryer models)

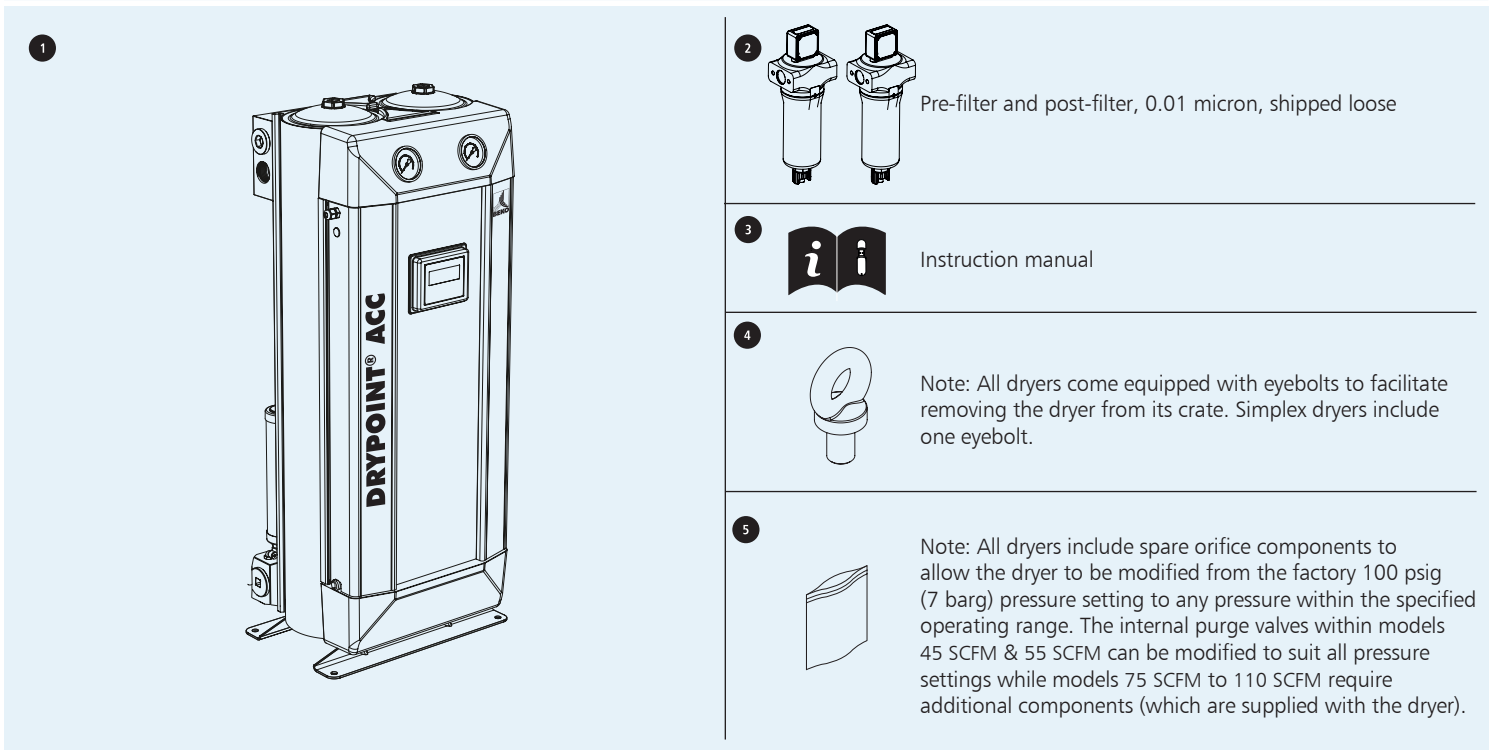
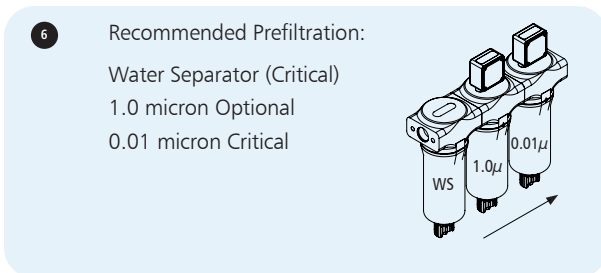

Figure 2.3: Strongly Recommended





## Section 2: General Description

Figure 2.4: Primary Components (Simplex Models 45 SCFM - 110 SCFM)

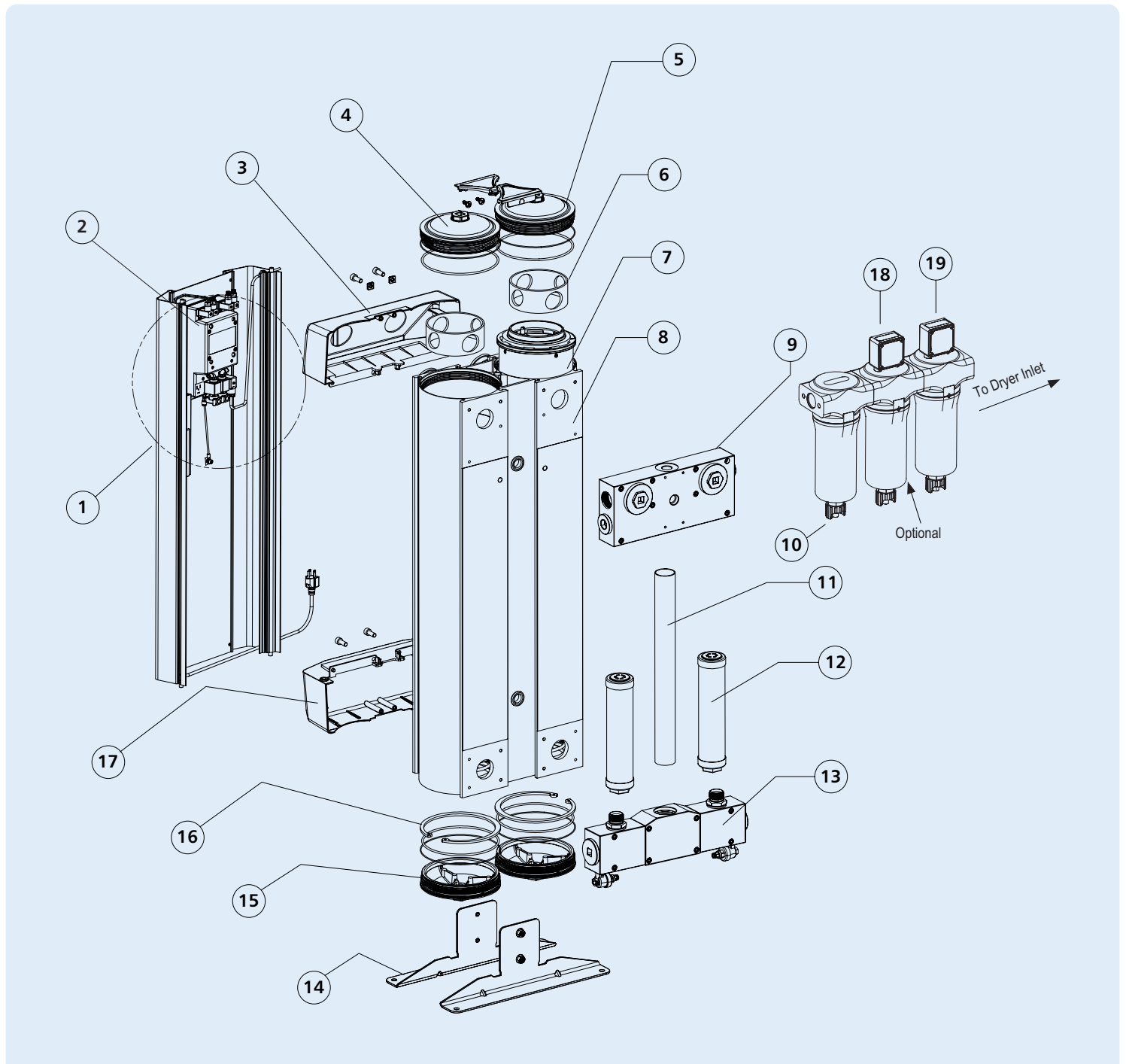

1. Front panel
2. Digital Display Controller
3. Top trim cover
4. Extrusion cover
5. Top extrusion tower plug
6. Tower Spacer
7. Desiccant cartridge
8. Extrusion tower

9. Top manifold assembly
10. Water Separator (recommended)
11. Downpipe
12. Exhaust silencer
13. Bottom manifold assembly
14. Dryer stand
15. Bottom extrusion tower plug
16. Tower circlip

17. Bottom trim cover
18. Pre-filter (general purpose) 1.0 μ
19. Pre-filter (high efficiency) 0.01 μ

# Technical Data

## Environmental Conditions

All dryers are designed to be safe under the following conditions:

- *Indoor use*
- *Altitude up to 6560 ft.*
- *Ambient temperature 41°F (5°C) to 122°F (50°C)*
- *Mains supply voltage fluctuations not to exceed +/- 10% of nominal*

For operation extended from the above conditions, please contact the manufacturer.



**Excessive vibrations from external sources may cause failure of this product.**

Rated Conditions		
Measurement	Performance	
Inlet pressure	100 psig	7 barg
Inlet temperature	95°F	35°C
Relative humidity of air at inlet	95%	
Pressure dewpoint, standard version	-40°F	-40°C

Specified Limitation for Operation		
Measurement	Performance	
Maximum inlet air pressure	188.5 psig	13 barg
Minimum inlet air pressure	58 psig	4 barg
Maximum ambient air temperature	122°F	50°C
Minimum ambient air temperature	41°F	5°C
Pressure dewpoint*	-4°F to -100°F	-20°C to -74°C
Electrical supply voltage	115 - 240 VAC 50-60 Hz or 24 VDC	

\* Pressure dewpoint dependant upon dryer sizing (see page 12). High performance cartridges required for -100°F (-74°C) operation.

Section 3: **Technical Data** 45 SCFM - 110 SCFM

Dryer model	Dryer Pipe size	Inlet flow rate*		Dimensions Inches (mm)						Weight lbs (kg)	No. of cartridges	Dryer config.	Filter pipe size
		SCFM	Nm <sup>3</sup> /hr	A	B	C	D	E	F				
ACC 46	1	45	77	25.7 (655)	14.0 (380)	12.2 (310)	3.0 (76)	1.96 (50)	23.6 (600)	101 (46)	2	simplex	½
ACC 56	1	55	94	28.9 (735)	14.0 (380)	12.2 (310)	3.0 (76)	1.96 (50)	27.5 (700)	112 (51)	2	simplex	½
ACC 75	1	75	128	35.6 (905)	14.0 (380)	12.2 (310)	3.0 (76)	1.96 (50)	33.4 (850)	137 (62)	2	simplex	¾
ACC 90	1	90	153	40.55 (1030)	14.0 (380)	12.2 (310)	3.0 (76)	1.96 (50)	39.3 (1000)	155 (70)	2	simplex	1
ACC 110	1	110	187	49.6 (1260)	14.0 (380)	12.2 (310)	3.0 (76)	1.96 (50)	27.5 (700)	187 (85)	4	simplex	1

\*Stated flows are for an inlet pressure of 100 psig (7 barg) with reference to -4°F, 14.50 psig (abs.), 0% relative water vapor pressure. For flow at other pressures apply the appropriate correction factors, temps and dewpoint.

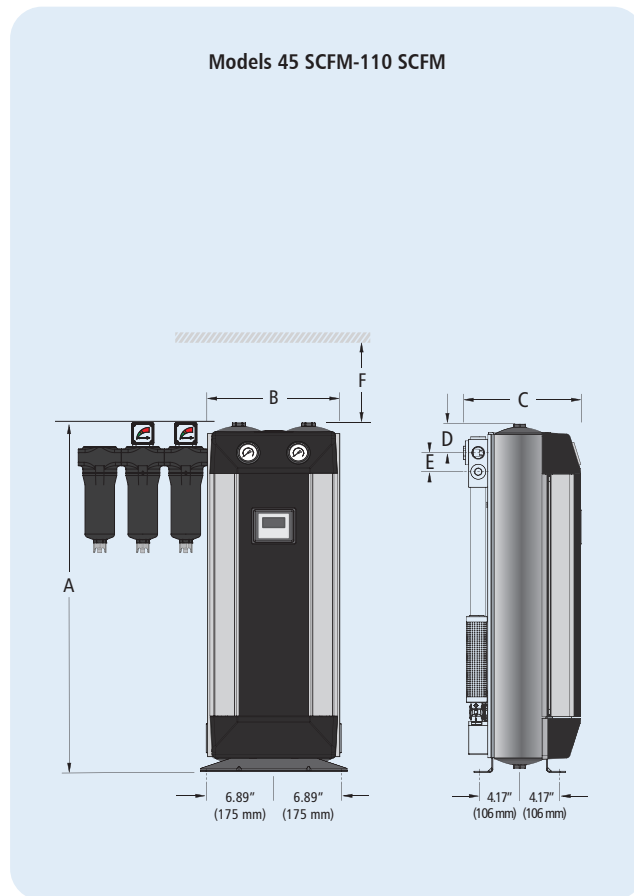

### Dryer correction factors

Operating pressure (PCF)										
psig	58	72	87	100	115	130	145	160	174	189
barg	4	5	6	7	8	9	10	11	12	13
Correction factor	0.62	0.75	0.87	1.0	1.12	1.25	1.37	1.50	1.62	1.75

Temperature (TCF)							
Fahrenheit °F	68	77	86	95	104	113	122
Celsius °C	20	25	30	35	40	45	50
Correction factor	1.3	1.2	1.1	1.0	0.75	0.65	0.45

Pressure dewpoint (DCF)					
Fahrenheit °F	-4	-22	-40	-94*	-100*
Celsius °C	-20	-30	-40	-70	-74
Correction factor	1.23	1.2	1.0	0.8	0.77

\* Only achievable when utilizing High Performance cartridges

### Dryer Sizing Example

To correctly select the dryer model suitable for your application the following information is required: Minimum Inlet Pressure, Maximum Inlet Temperature, Maximum Compressor Inlet Flow and Required Pressure Dewpoint (PDP).

Requirements		Correction Factor
Maximum compressor inlet flow	56 scfm	-
Actual minimum inlet pressure to the dryer	87 psig	PCF = 0.87
Maximum inlet temperature	77°F (25°C)	TCF = 1.2
Pressure dewpoint (PDP)	-100°F (-74°C)	DCF = 0.77
Corrected dryer flow rate	$\frac{\text{Inlet flow rate}}{\text{PCF} \times \text{TCF} \times \text{DCF}} = \frac{56}{(0.87 \times 1.2 \times 0.77)} = \frac{69.7 \text{ scfm}}{(118 \text{ Nm}^3/\text{hr})}$	
Appropriate Dryer Size	Dryer model is selected based on the corrected flow rate, i.e. 75 SCFM.	

### Technical notes

1. Pre-filtration, including a Water Separator is essential to maintain dryer performance.
2. An appropriate Water Separator must be installed. If bulk water enters the adsorption dryer it can cause heat expansion to the desiccant, substantial rise in the dryer differential pressure, poor outlet dewpoint, potentially resulting in dryer failure.
3. The manufacturer recommends fitting a reverse flow 0.01 micron dust filter to the outlet.
4. Call your nearest manufacturer sales team for further information.

# Mechanical Installation

Figure 4.1: Typical installation

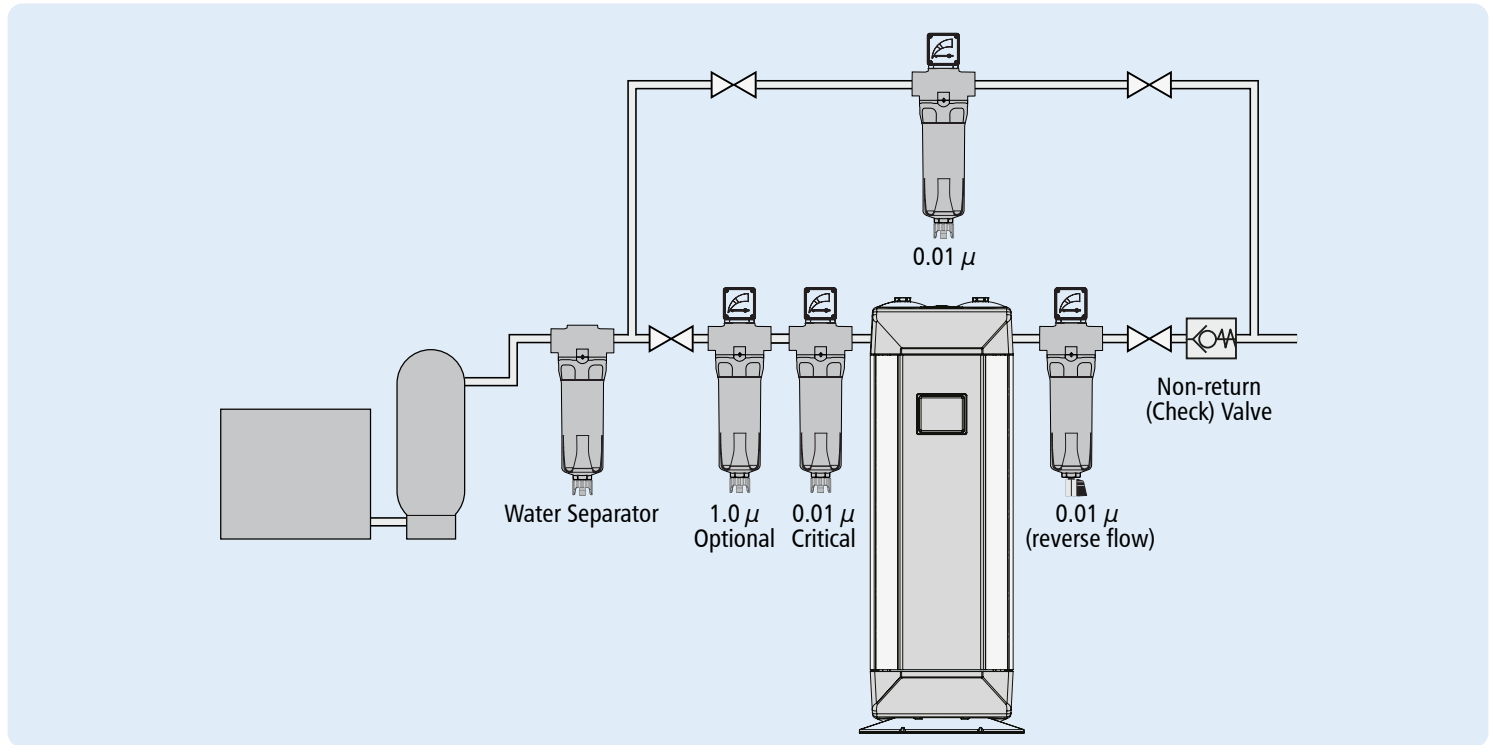

To prevent back flow into the dryer a non-return valve should be placed in-line, downstream of the dryer. This is essential when more than one dryer is used in a single application.

Figure 4.2: Level ground

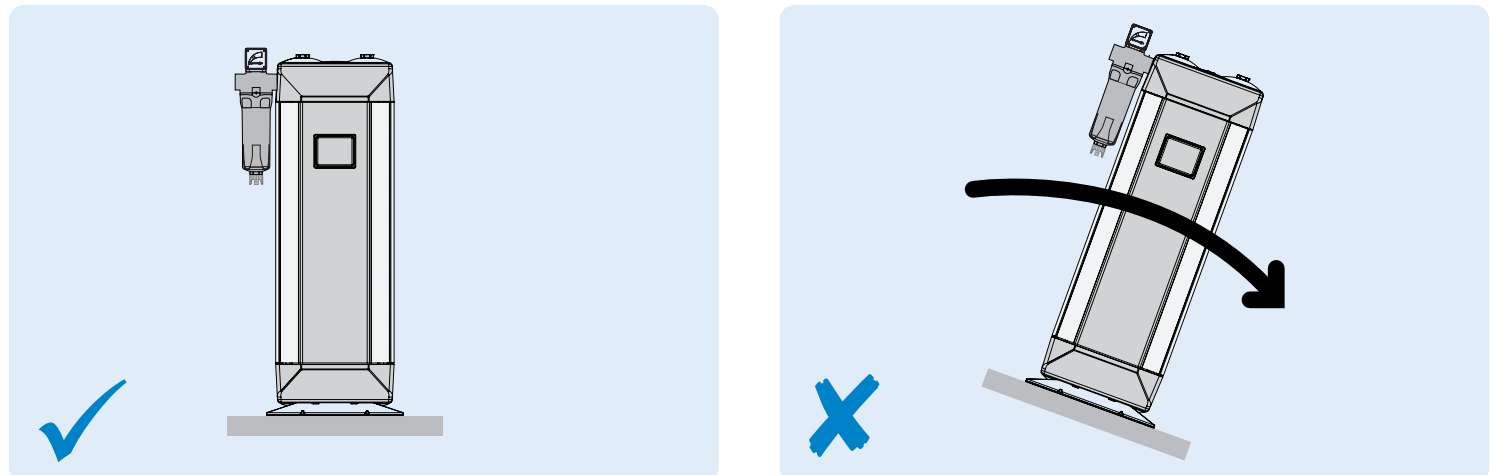

## Section 4: Mechanical Installation

Figure 4.3: Location

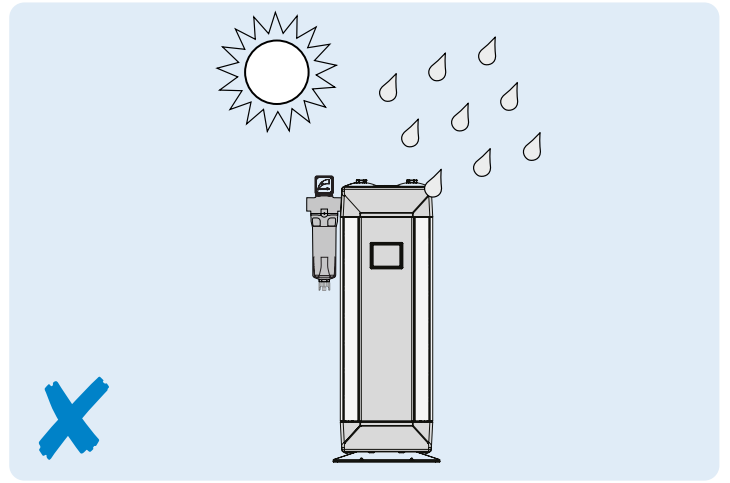
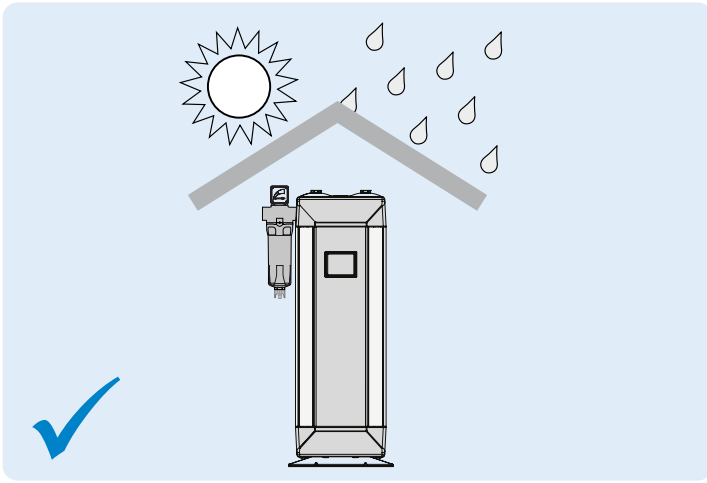

Figure 4.4: Hard piped installation

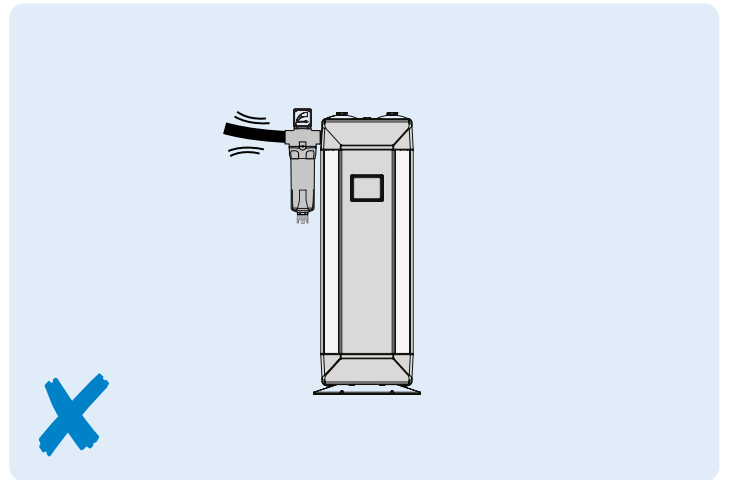
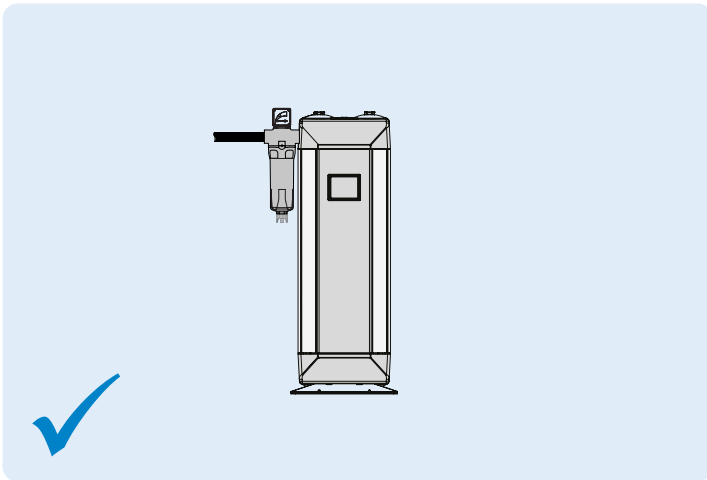
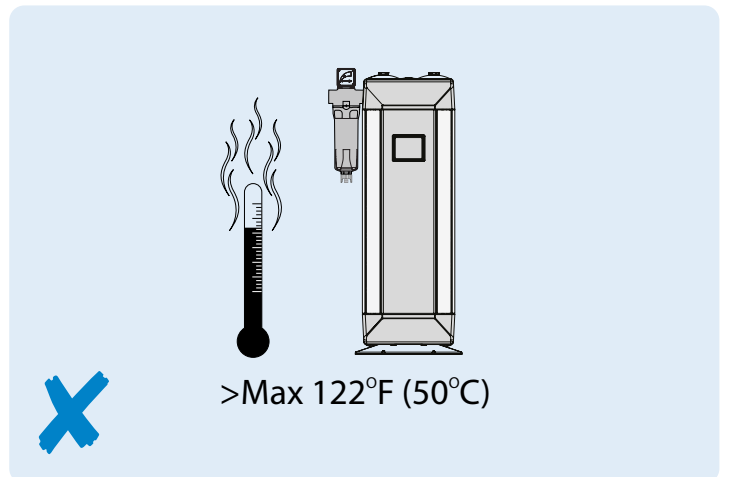
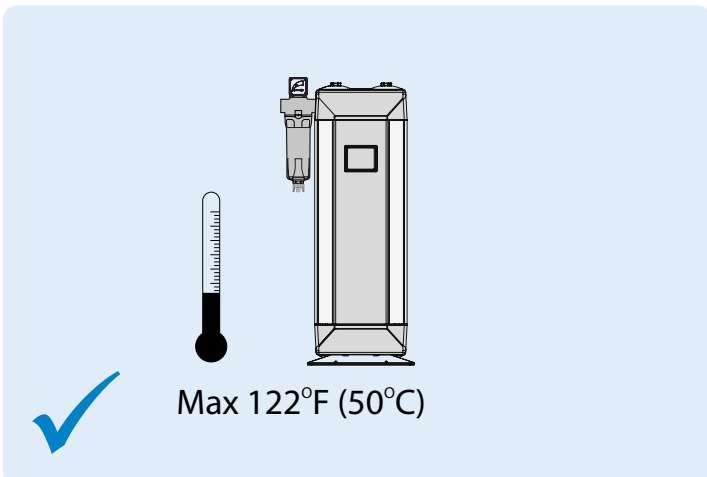
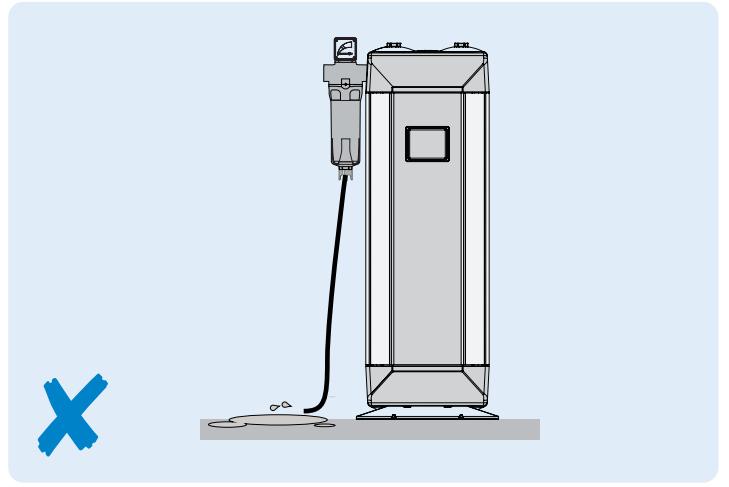
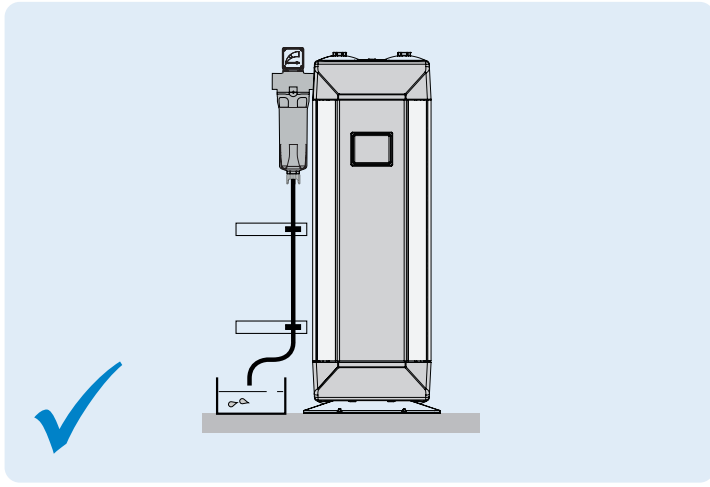

Figure 4.5 Exposure to heat



## Section 4: Mechanical Installation

Figure 4.6: Drainage (all tubing should be secured up to the point of drain to prevent whipping during discharge)



## Orientation

Figure 4.7: The range of dryers is designed to operate in both vertical and horizontal orientation.

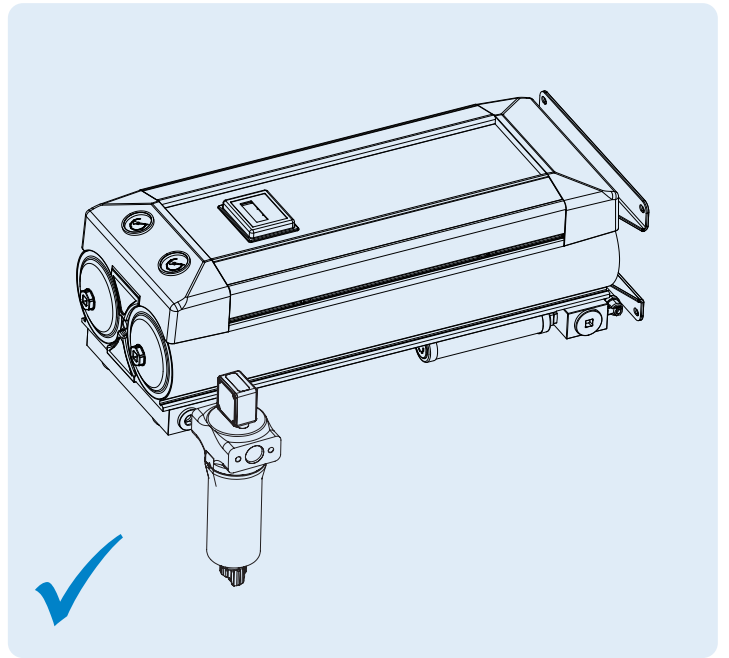
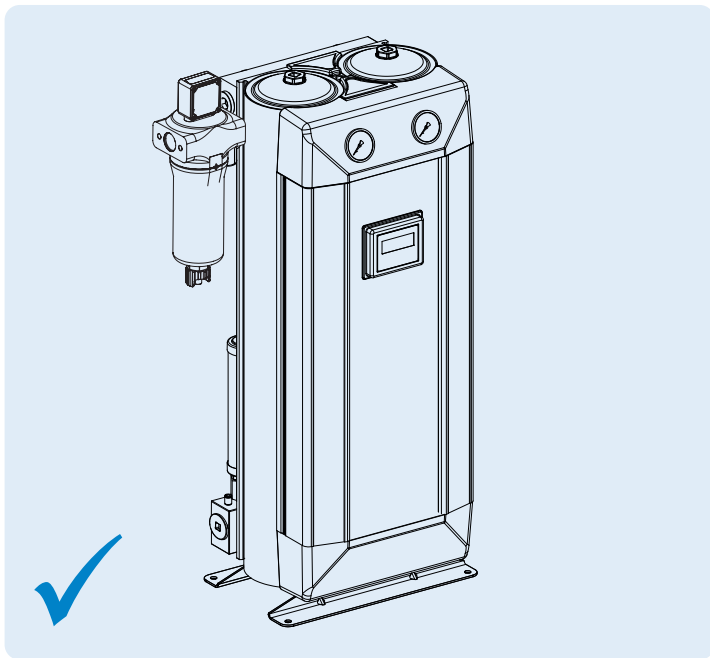

**Re configuration of the inlet / outlet ports**

**45 SCFM - 110 SCFM models**

- Dryer can be reconfigured to interchange position of inlet and outlet ports as per figure 4.8.
- The dryer has two inlet ports (A and B) and two outlet ports (C and D). Either (A or B) can be used for inlet and (C or D) for outlet. Make sure the un-used ports are blanked off with provided pressure plugs.

Figure 4.8: Inlet/outlet ports

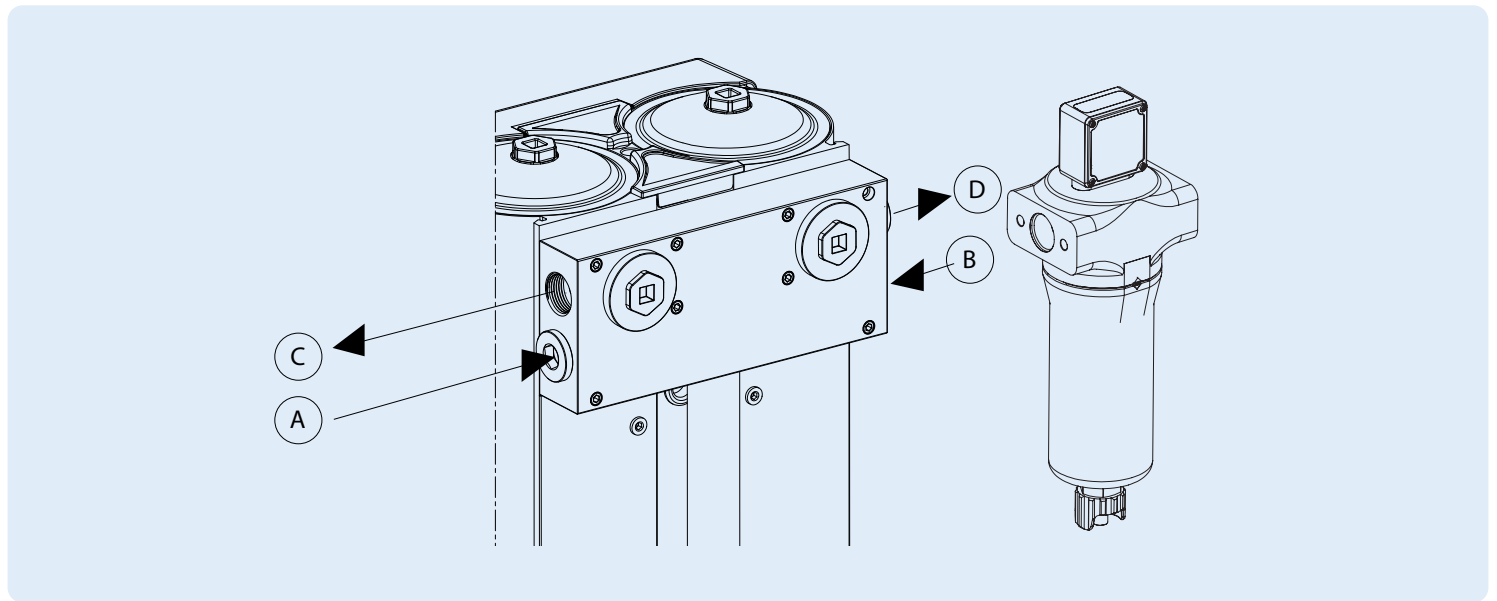

Either of the two outlet ports can be used. Please ensure that the outlet flow does not exceed specification. Please adhere to regional regulations.



It is strongly advised to install a non-return (check) valve to the outlet port of the dryer.



Only use one inlet port at any one time.



Ensure original seals are in place.



Check dryer is leak-free prior to operation.



Ensure that any surges in flow do not exceed the dryers rated flow capacity.

**Tools required**

- Adjustable wrench
- Ratchet with 17mm Hexagonal connection (45 SCFM - 110 SCFM)



### Connecting the pre-filter to the dryer

#### 45 SCFM - 110 SCFM models

- Attach CLEARPOINT pre-filter (shipped loose for field installation) utilizing a pipe nipple and/or pipe adapter (user supplied).
- Pipe away condensate with tubing from drain outlet. Ensure condensate is drained into an oil/Water Separator.
- Fit any additional filtration and/or ancillary equipment.
- Pre-filter is typically supplied with a float drain installed in the bowl drain port. This can be replaced with the optional BEKOMAT® drain.



All tubing should be secured up to the point of drain to prevent whipping during discharge.

- It is recommended that a bypass line including an 0.01 micron filter is installed, as per figure 4.1.

Figure 4.9: Connecting a pre-filter

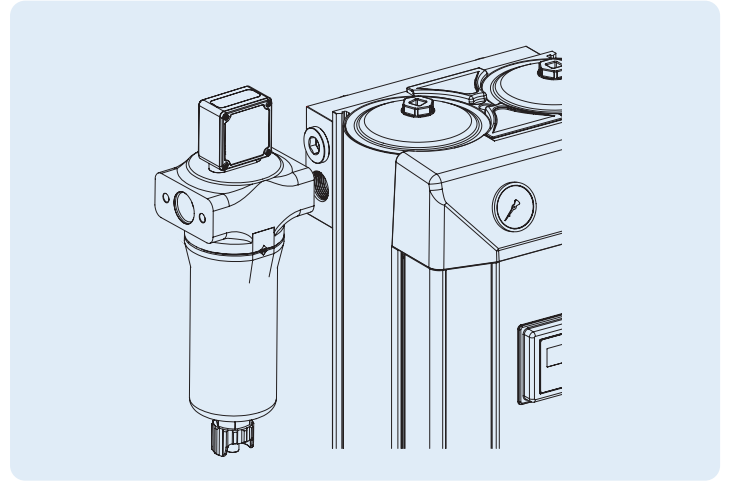

### Connecting the post-filter to the dryer

#### 45 SCFM - 110 SCFM models

- Attach CLEARPOINT post-filter (shipped loose for field installation) utilizing a pipe nipple and/or pipe adapter (user supplied).
- Fit any additional filtration and/or ancillary equipment.
- Post-filter is typically supplied with a manual drain installed in the bowl drain port.

Figure 4.10: Connecting a post-filter

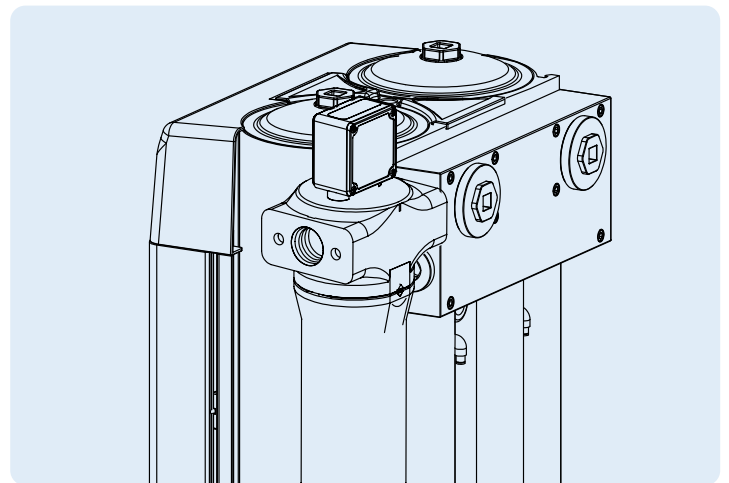

Purge Orifice Size Identification

- Reference figure 4.11 and the Purge Plug Identification Table.
- Each dryer is pre-set with the correctly sized purge valve for an operating pressure of 100 psig (7 barg) at point of order.
- The lettering (A through S), located on the purge valve body, indicates the orifice size selected to suit the operating pressure of the dryer per the chart below.
- If the inlet pressure to the dryer will be different than the pre-set orifice size, the purge valve can be adjusted.
- Dryers use a single orifice purge valve represented by the Red and Blue single letter references in the table below.
- To select the correct orifice size, locate the appropriate dryer model at the left side of the table and then the operating pressure at the top.
- Make sure that the correct orifice disc (01, 02) has been supplied with the dryer. The discs have the number (01, 02) stamped out at the top.

Purge Plug Identification										
Operating pressure psig (barg)	58 (4)	73 (5)	86 (6)	102 (7)	116 (8)	131 (9)	145 (10)	160 (11)	174 (12)	189 (13)
Dryer										
ACC 46	M	K	I	H	G	F	E	E	E	D
ACC 56	P	M	L	K	J	I	H	G	F	F
ACC 75	B	S	P	M	L	L	K	I	I	H
ACC 90	C	A	P	P	N	L	K	J	I	H
ACC 110	I	E	C	A	P	M	K	K	J	I
HYG-BLEED	1 ½	1 ¼	1 ¼	1 ½	1 ½	¾	¾	¾	¾	½

Disc

	01
	02



Every dryer is shipped with a purge orifice set up for 100 psig (7 barg) operation. The dryer will also include the necessary purge valve components to configure the dryer to operate at any pressure from 58 psig (4 barg) to 189 psig (13 barg). For example: A 110 SCFM dryer will be supplied with a single hole purge assembly with an 02 purge disc installed and indexed to position A. Additional purge valve components will be included to allow the dryer to be configured to purge settings, CK, M, G, C, B, A, S, S and P.



Appropriate purge plug selection is very important for function of the dryer. Failure to comply with this may affect your warranty.

Figure 4.11 Purge valve assembly

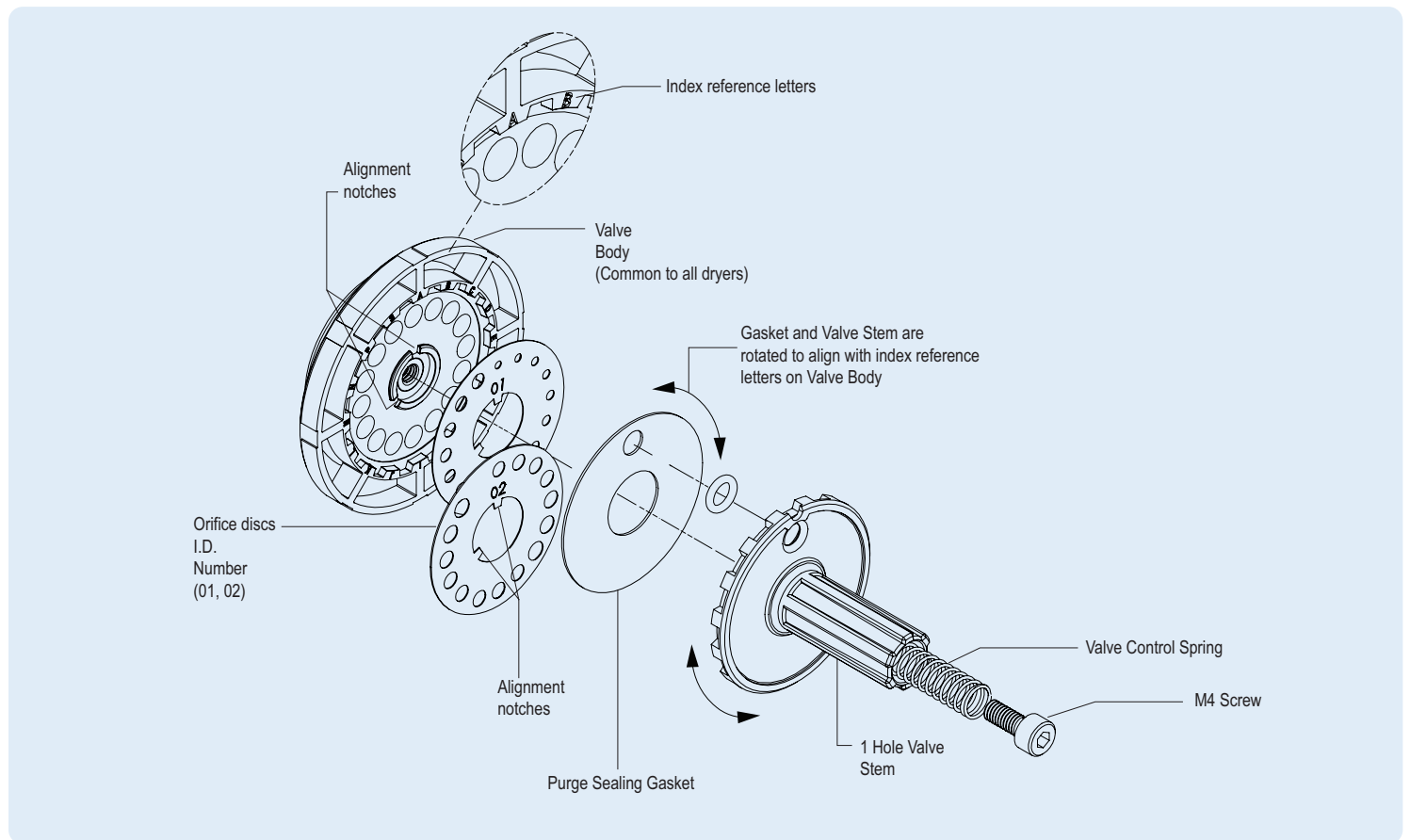

### Purge Valve Assembly

- Reference figure 4.11 and the Purge Plug Identification Table on Page 18.
- Once the correct orifice disc (01 or 02) has been selected per the instructions on Page 18, the purge valve may be assembled.
- The index letters located on the purge valve body correspond with the selected orifice sizes per the Table on Page 18.
- Place the appropriate orifice disc onto the valve body, taking care to align the notches. The disc will only fit in one position.
- Place the valve stem O-ring into its corresponding recess on the back of the valve stem.
- Align the hole in the purge sealing gasket with the corresponding hole in the valve stem.
- Rotate the valve stem assembly so that the correct orifice letter(s) aligns with the notches corresponding to the hole in the valve stem.
- Press the assembly together and fasten with the M4 screw.
- Double check to make sure that the open orifice hole corresponds with the correct orifice selection as identified earlier.

# Electrical Installation

---

## Controller power supply options

---

### **Models 45 SCFM - 110 SCFM**

- The dryer is designed to operate on either AC or DC supply voltage.
- Dryers are supplied with AC power supply and attached 115VAC USA power cord. The power supply may be removed to allow 24VDC to be supplied directly to the controller. Reference Figure 5.1 for details on controller power supply connections.

**Controller Specifications**

Ambient temperature	35°F to 122°F (5°C to 50°C)
Input voltage range (115 - 240 VAC or 24VDC*)	Power Rating 16W (Max)
Protection class	IP65

\* Attached 115 - 240 VAC to 24VDC power supply may be removed to allow 24 VDC power to be connected directly to the controller.

\*\* A 3 amp fuse should be fitted as per the wiring diagram.

Figure 5.1: Controller electrical connections

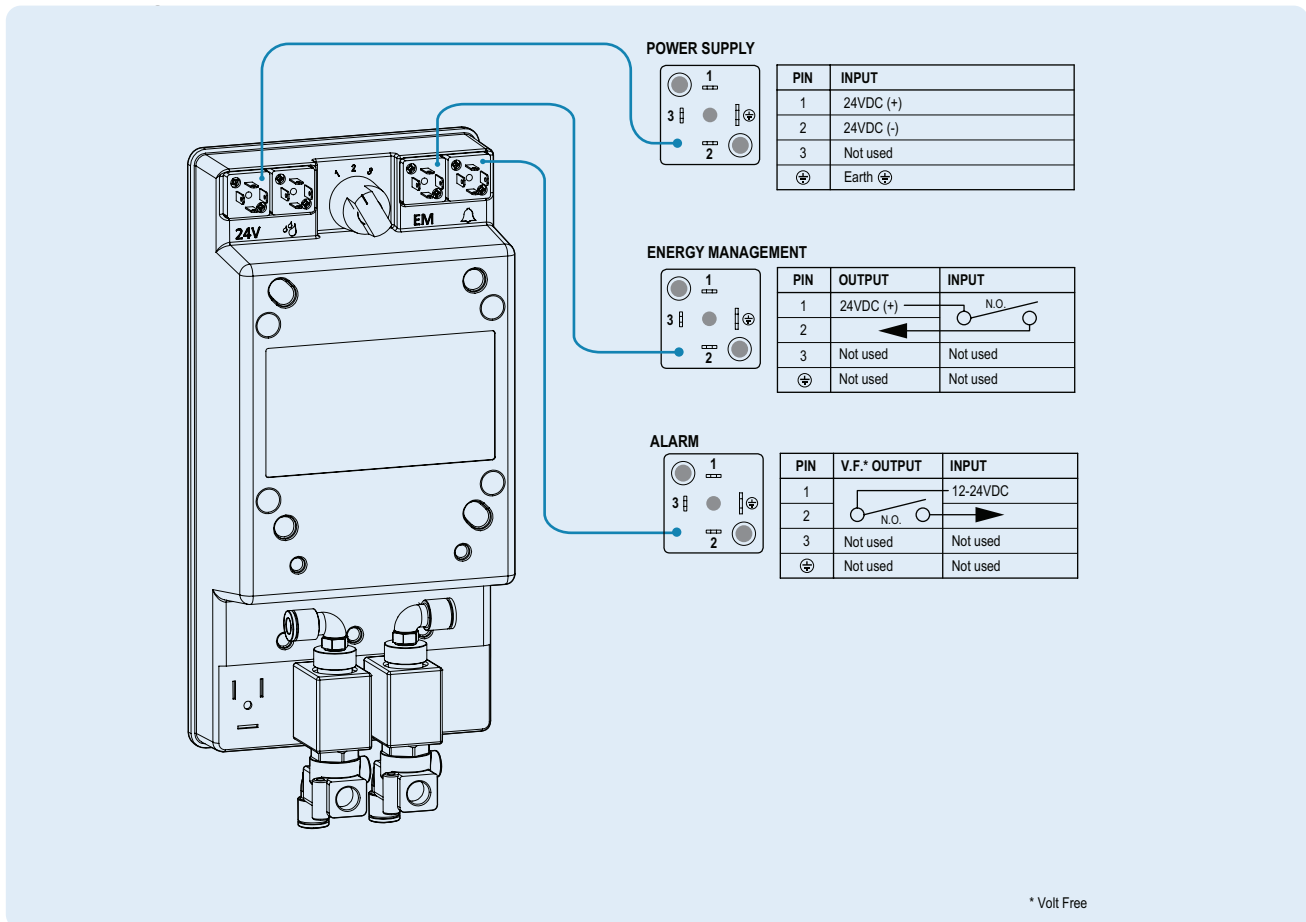

### How to wire a DIN connector

#### Models 45 SCFM - 110 SCFM

- Locate the DIN connector on the back of the controller.
- Remove the screw completely from the centre of the connector.
- Remove the blanking plug, if present, from the connector and discard.
- Insert a small flat screwdriver into the small recess at the edge of the insert, pry the insert out of the DIN connector's outer shell per figure 5.2.
- Per figure 5.3, slip cable end through DIN connector's cable gland, washer, grommet and out through the front of the DIN connector case.



**Cable diameter should be no greater than 1/4" (6mm). Larger diameters do not fit well into the cable gland of the DIN connectors.**



**Cable should be round as rectangular cable or ribbon cable will not seal properly in DIN connectors grommet.**

- Strip the outer insulation of the cable back approx 3/4" (20mm).
- Strip the conductor insulation back approx 1/8" (3mm).
- Insert conductors into appropriate pins of insert. Tighten retaining screws securely.
- Determine which direction the cable gland should point.
- Carefully pull the cable back through the case until the insert snaps back into place. Take care to work the wires around the retaining screw hole as they can become fairly easily pinched.
- Plug the DIN connector back onto the appropriate electrical connection on the back of the dryer's controller per figure. Take care to make sure that sealing gasket is in place.



**The male ground pin is slightly wider than pins 1 & 2. Take care to ensure that the female connector is oriented correctly.**

Figure 5.2: DIN connector

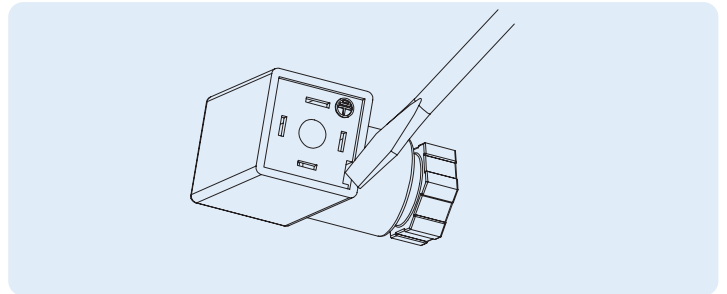
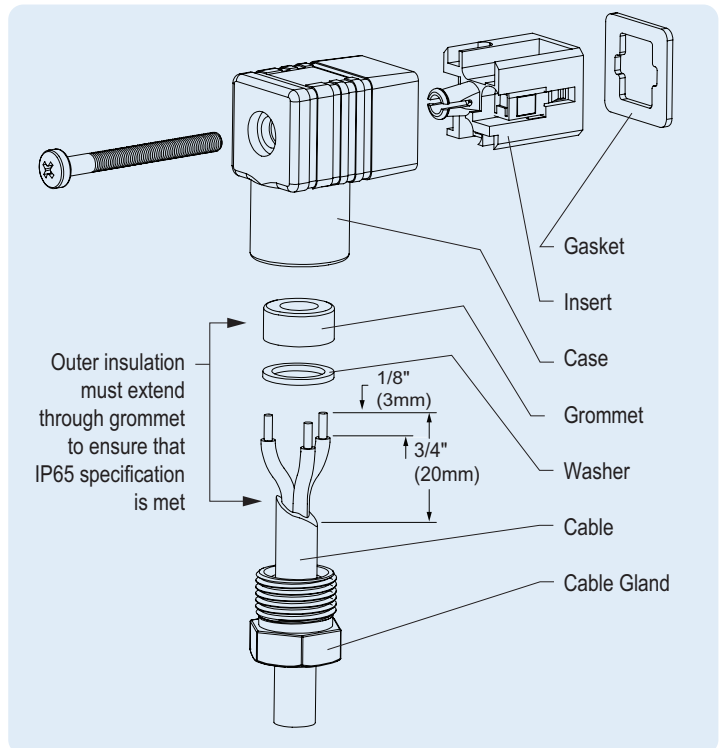

Figure 5.3: DIN connector for Digital Display Controller



**Alarm connection details**

**Models 45 SCFM - 110 SCFM**

- To enable the alarm facility, it is recommended that a suitable cable is brought into the controller via the rear panel with a grommet. An external power source is required.
- Per Figure 5.4 Digital Display Controller, connect the switching pole of an externally powered alarm indication device to the corresponding terminals of the controller's alarm output.

Fig 5.4 Alarm contact connections Digital Display Controller

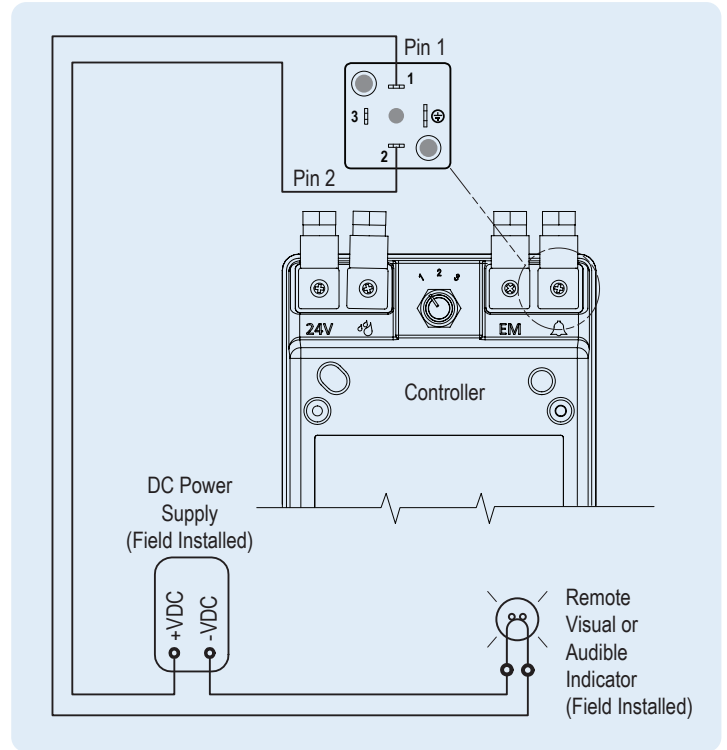

For details regarding wiring of female DIN connector refer to "How to wire a DIN connector" on page 22.

**Alarm Connection Details**

Hirschmann GDS 207 industrial std DIN connector or equivalent

Alarm Contact Rating (Digital Display Controller)	0.5 AMPS 24VDC
---	----------------

# Operation

---

## Background / Function of the dryer

---

The dryer is designed to provide a smooth, controlled and uninterrupted delivery of dry compressed air. Wet air passes through a pre-filter and travels down to the bottom valve assembly. The air is then fed through the bottom of the desiccant bed and moves through the high performance desiccant until it becomes dry. On exit from the desiccant cartridge, the air is passed through the outlet valve assembly.

During this process, the dryer control system cycles the process air between the two desiccant towers. While one tower is on stream removing water vapor, the other is being carefully depressurized in preparation for regeneration. The desiccant bed is regenerated by expanding a small amount of dry process air, or purge air, through the saturated desiccant.

Purge air passes to atmosphere through the silencer, which is fitted to an exhaust valve. The chamber is then repressurized, with the control system assuring each chamber is at full operational pressure prior to changeover.

This ensures a reliable and efficient operation. The air stream is switched and the cycle repeats on a continuous basis.

---

## Detailed Operational Description - Digital Display Controller

---

- Refer to detailed operational schematics, figure(s) 6.3 - 6.8.
- Controller operates on a standard timed cycle as detailed in Figures 6.3 through 6.8.
- Operational status is displayed in text form on the LCD display..



## Section 6: Operation

- Purge loss may be reduced during periods of low or no air demand. The Energy Management Feature (EM) may be utilized in this case. A detailed description is given in Section 7.
- For remote indication of any electrical faults, the Alarm Contacts may be utilized to send a signal to a light or remote service panel. Further details are given on page 23.

Figure 6.2: Typical installation

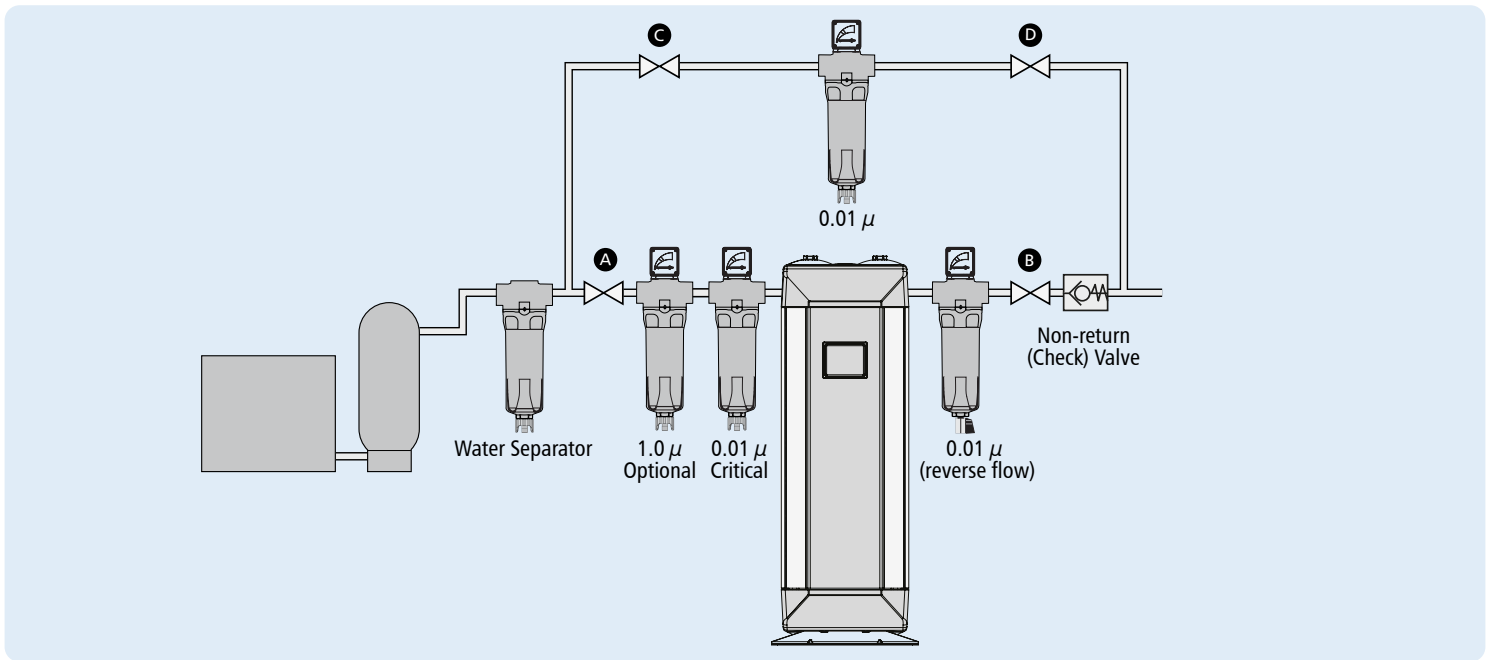

### Start-up procedure

- Refer to figure 6.2.
- Close valves A, B, C and D.
- Switch on compressor.
- Open valve A slowly.
- Check there are no leaks from the dryer.
- Switch on electric power, the panel will display the operational features.
- The dryer will enter standard cycle mode.
- Open valve B slowly.

### Shut-down Procedure

- Close valve B.
- Close valve A.
- Leave dryer running for 15 minutes to fully de-pressurize.
- Switch off all electrical power to the dryer.

**Under no circumstances must compressed air be allowed to flow through the dryer following switch off of electrical power. This will result in terminal failure of the desiccant cartridges and regeneration will not be possible.**



**On initial commissioning, run the dryer for a minimum of 6 hours to ensure dewpoint is adequate before utilizing the Energy Management feature.**

## Section 6: Operation

Figure 6.3: Initial Pressurization (Power Off)

- With power off to the dryer, both towers pressurize to line pressure. The N.O., 3/2 solenoid valves are de-energized and therefore, are in an open position. The air supply through the solenoid valves forces the exhaust shuttles into a closed position, and the dryer remains air-tight.
- Note: Any air flowing through the dryer, passes through both towers.

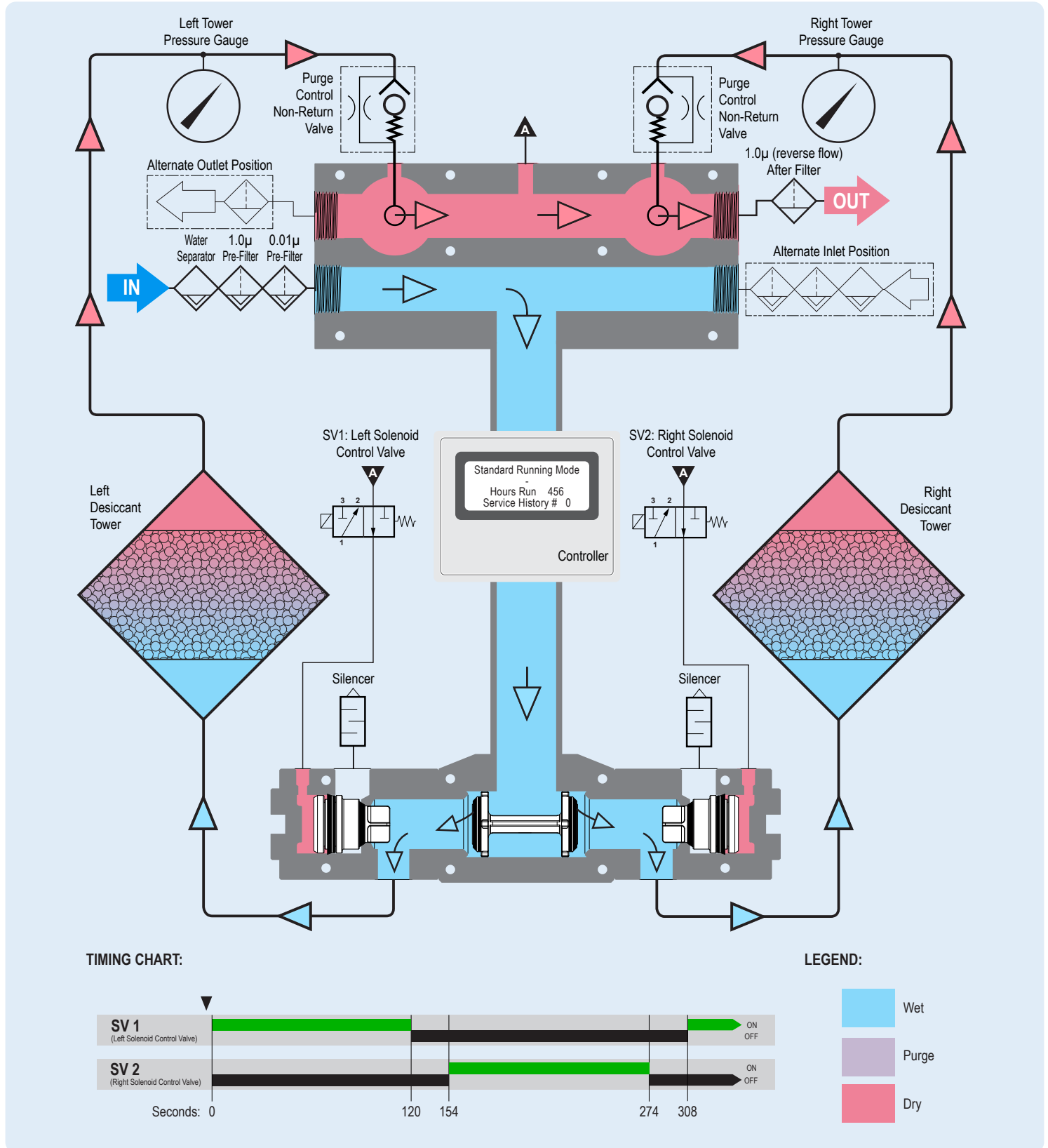

## Section 6: Operation

Figure 6.4: Stage 1: Left Tower Purging, Right Tower Drying

- After an initial 40 second delay the left solenoid is energized and therefore switches spool position releasing the compressed air behind the exhaust shuttle. This allows the left exhaust shuttle to open allowing air to rush from the left tower out of the silencer as it depressurizes. For 120 seconds, a bleed of dry air from the outlet of the on-stream (right) tower is directed through the left purge orifice and down through the left tower to regenerate the off-stream (left) desiccant bed.

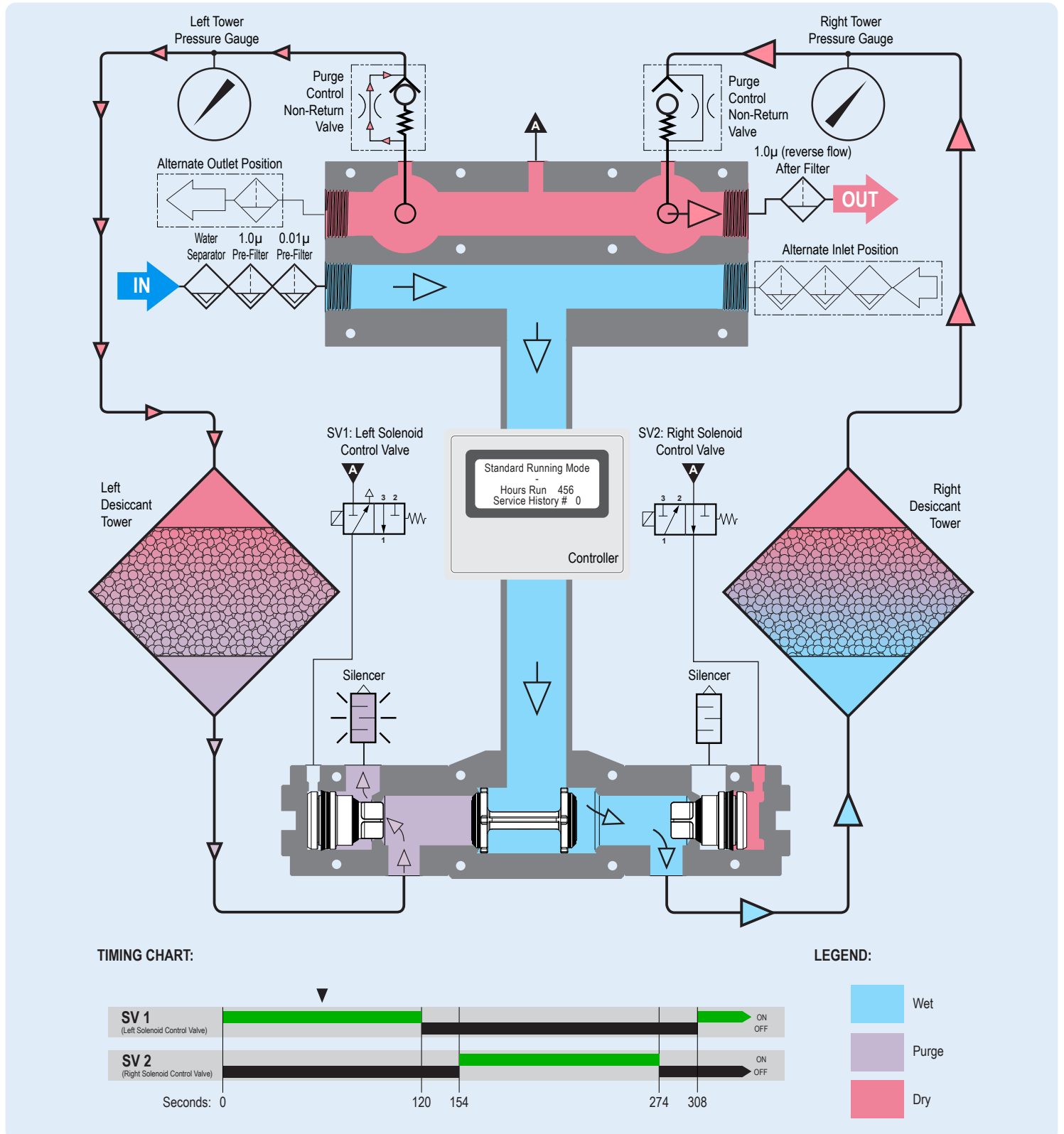

## Section 6: Operation

Figure 6.5: Stage 2: Repressurization

- At completion of Stage 1, the left solenoid is de-energized and switches spool position allowing the air supply through the solenoid to close the left exhaust shuttle. The left tower then repressurizes for a 34 second period.
- Note: Any air flowing through the dryer, passes through both towers.

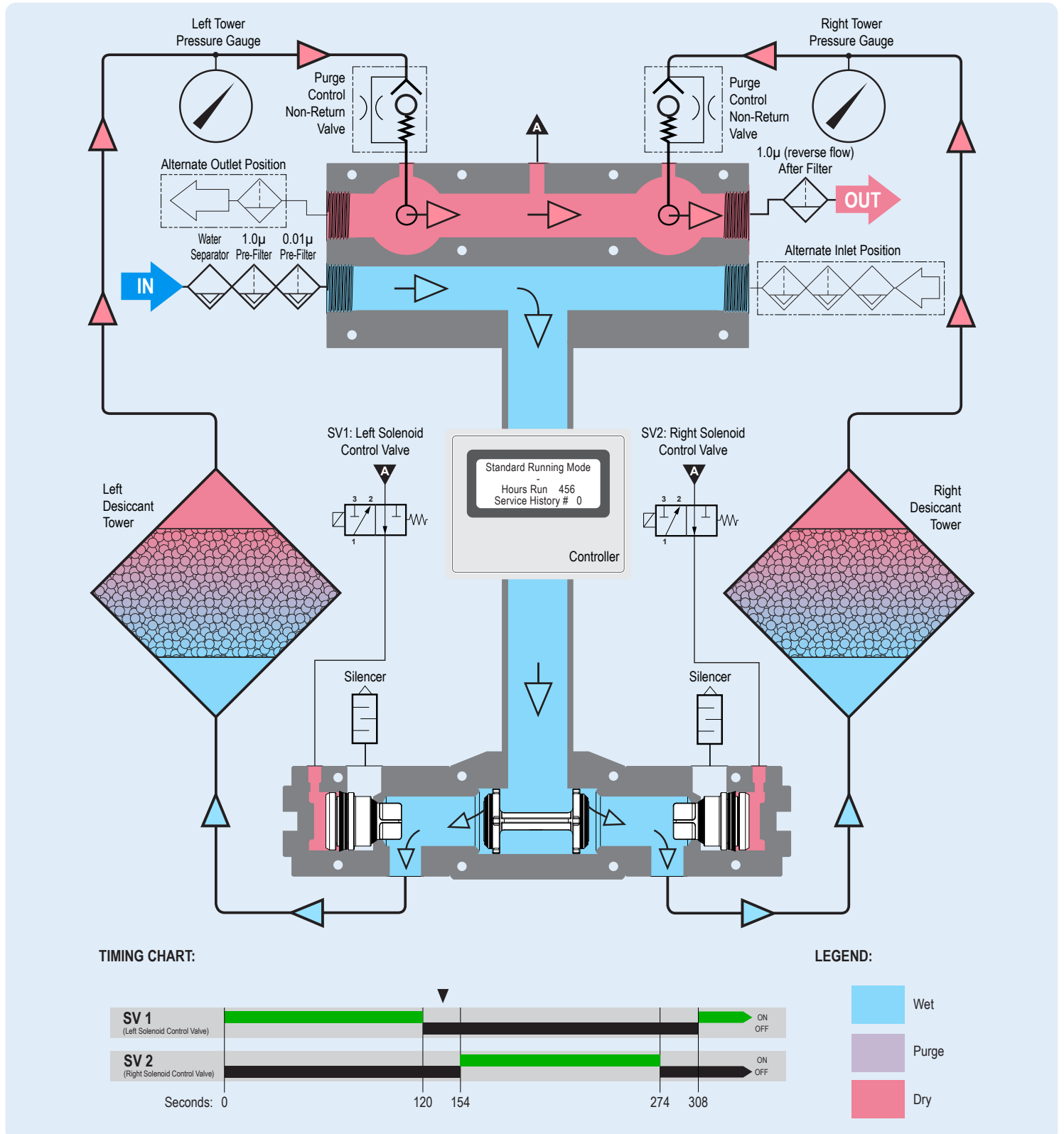

## Section 6: Operation

Figure 6.6: Stage 3: Left Tower Drying, Right Tower Purging

- At the completion of Stage 2, the right solenoid is energized and therefore switches spool position releasing the compressed air from behind the exhaust shuttle. This allows the right exhaust shuttle to open allowing air to rush from the right tower out of the silencer as it depressurizes. For 120 seconds, a bleed of dry air from the outlet of the on-stream (left) tower is directed through the right purge orifice and down through the right tower to regenerate the off-stream (right) desiccant bed.

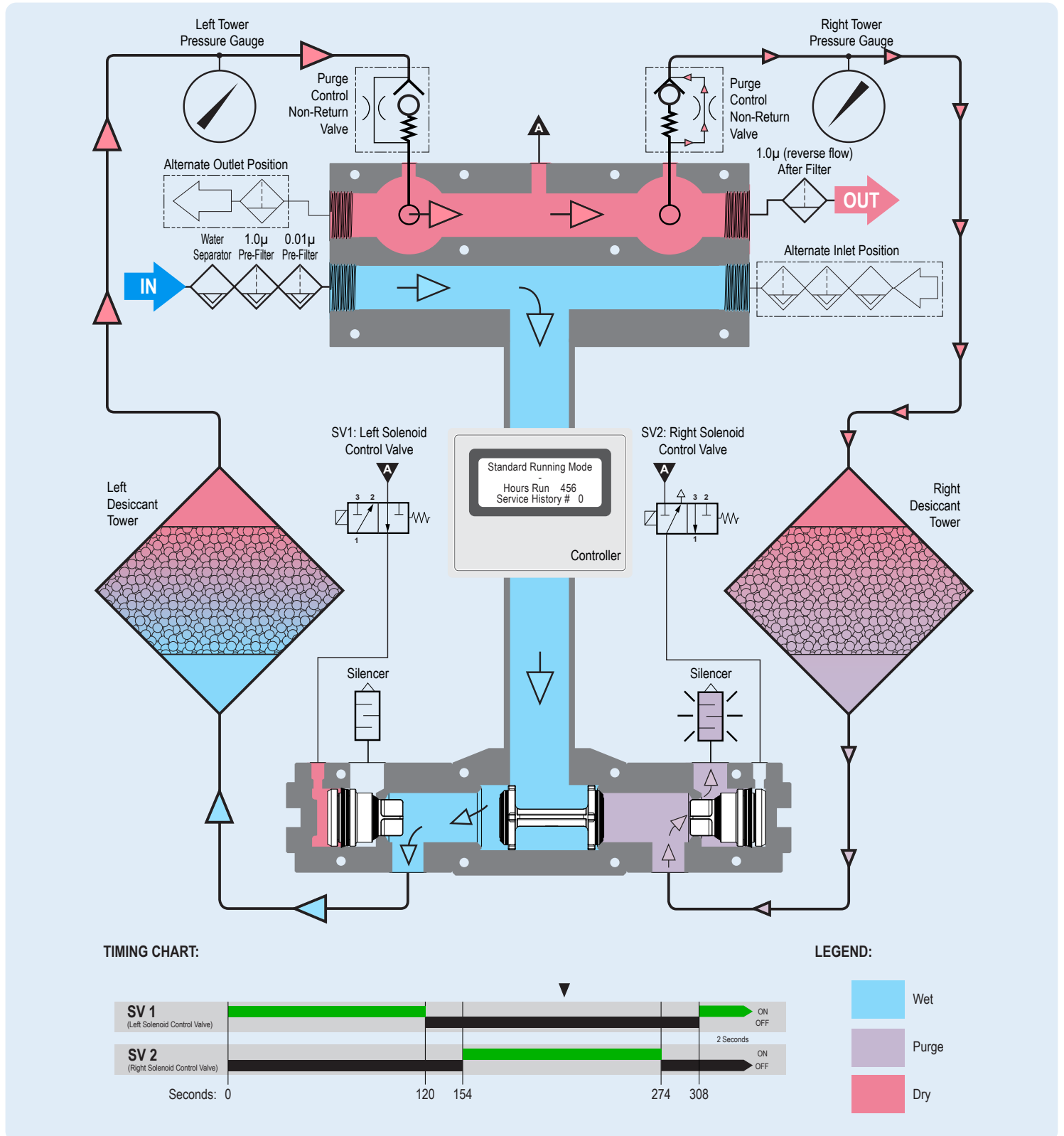

## Section 6: Operation

Figure 6.7: Stage 4: Repressurization

- At completion of Stage 3, the right solenoid is de-energized and it switches spool position to allow the air supply through the solenoid to close the right exhaust shuttle. The right tower then repressurizes for a 34 second period.
- Note: Any air flowing through the dryer, passes through both towers..

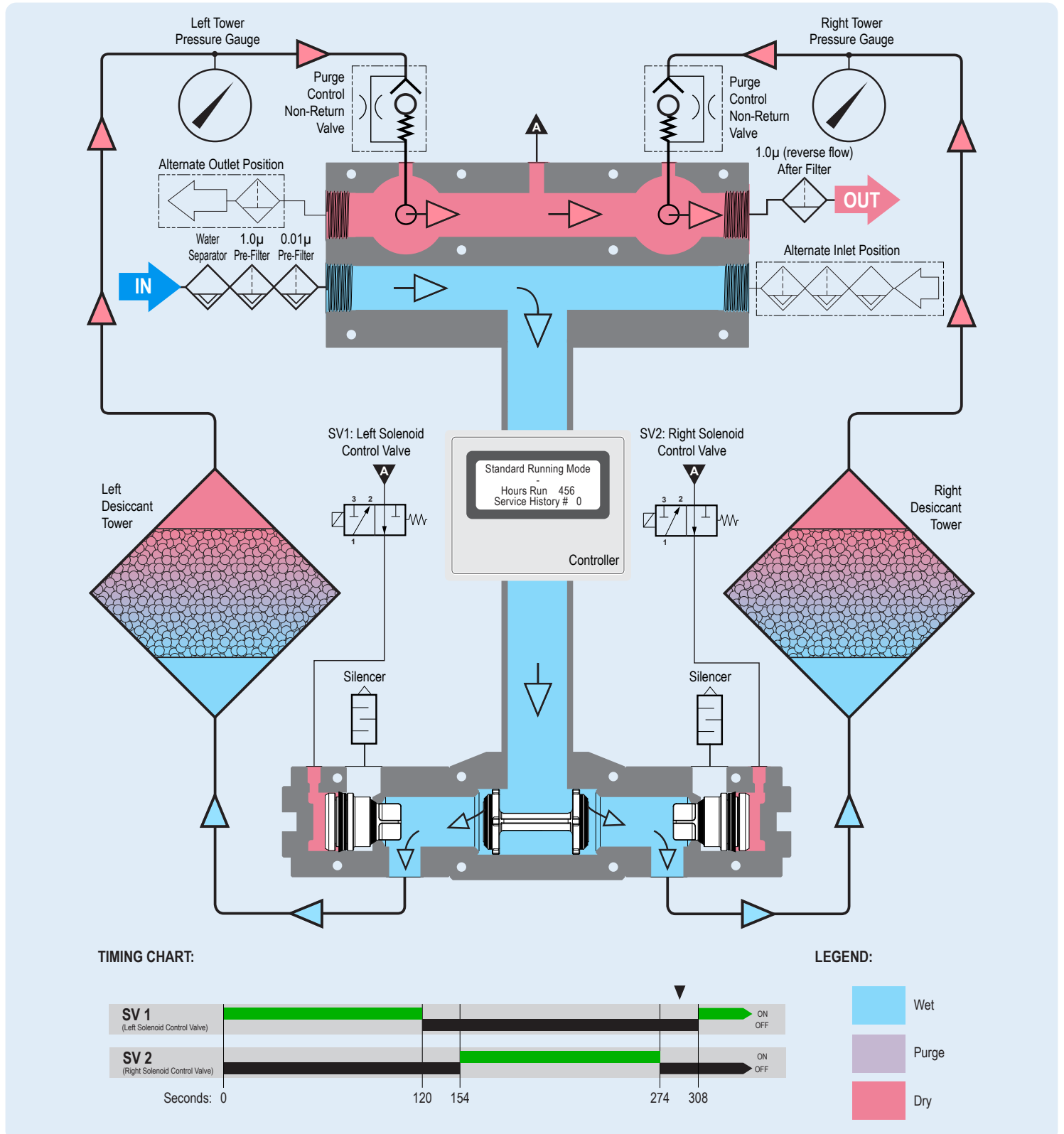

# Energy Management

## Overview

Regenerative dryers must expel a portion of the process air in order to free themselves of accumulated moisture. During periods of low air demand, however, this air loss is not necessary and is therefore undesirable. In many cases, the compressor runs almost continuously in order to keep up with the dryer's purge loss.

All dryers are equipped with an Energy Management feature that allows the purge to be shut off during periods of low or no demand. The dryer controller is fitted with a set of field accessible contacts, that can be employed to shut off the solenoid valves which control the purge function of the dryer, therefore eliminating any air loss from the dryer.

## Developing a Purge Control Strategy

In order to utilize this function, the operator must provide a switching system that provides acceptable logic to indicate to the dryer that there is little or no air demand. On the following pages, some examples of commonly used switching systems are provided in ascending order of complexity.

## Using a Manual Switch for Purge Control

The simplest of arrangements, a manual switch may be employed to shut the purge off when the air downstream of the dryer is not being used. Commonly used on point of use systems. For example, if the dryer is only used to supply air of an appropriate dryness to a specific machine or application, the dryer will only be required when the machine is in use and may be shut off either manually or possibly via extra contacts provided in the machine's on/off switch.

It is extremely important to understand that the purge may only be shut off during periods of low or no demand. This feature, if used otherwise, can result in permanent damage to the desiccant beds resulting in loss of drying capacity and possibly mechanical failure. The cartridges must not be allowed to become fully saturated at any time.

The following schematic (Fig 7.1) offers an overview of the devices mentioned as they might be connected for use in controlling a dryer's purge function. Please note that specific details differ between device manufacturers, so in all cases the manufacturer's specifications should be adhered to.

Fig 7.1 Manual switch purge control

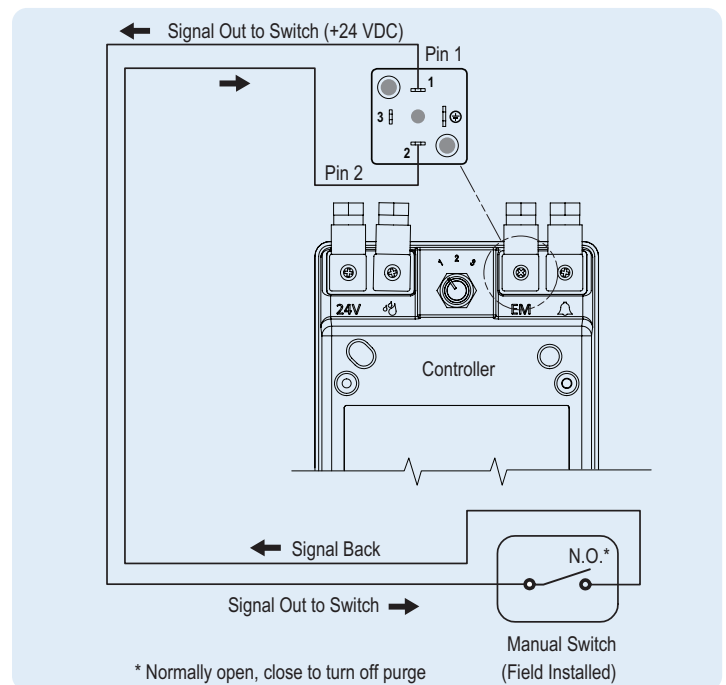

Using a Standard Pressure Switch for Purge Control

Many compressors come equipped with pressure switches with extra contacts that can be utilized to switch off the dryer’s purge when the compressor is in an unloaded state. Unfortunately, many of these switches have significantly large dead bands (difference between the load (on) and unload (off) settings that in most cases cannot be altered). The amount of air that can pass downstream, through the dryer, while the compressor is unloaded must be taken into consideration as it can be significant, especially if there is a large dead band and/or large wet receiver.

Often, a stand-alone pressure switch is a better option as it allows the user to adjust it independently from the compressor’s pressure switch. When selecting a stand-alone pressure switch, the smaller the dead band the better.

When using a stand-alone pressure switch, the dryer is wired into the open (Digital Display Controller) contacts on the pressure switch. When the switch is actuated (at 100 psig in the example), the purge shuts off until the pressure switch deactuates (at 95 psig in example). The point at which the switch deactuates, may be adjusted to suit the system.

If it is determined that the dewpoint drops to an unacceptable level, the deactuation point must be increased. Please note that with most standard pressure switches, the dead band is fixed such that the activation and deactuation points move together.

It is extremely important to understand that the purge may only be shut off during periods of low or no demand. This feature, if used otherwise, can result in permanent damage to the desiccant beds resulting in loss of drying capacity and possibly mechanical failure. The cartridges must not be allowed to become fully saturated at any time.

Figure 7.2 offers an overview of the Pressure Switch device mentioned as it might be connected for use in controlling a dryer’s purge function. Please note the specific details differ between device manufacturers, so in all cases the manufacturer’s specifications should be adhered to.

Fig 7.2 Standard pressure switch purge control

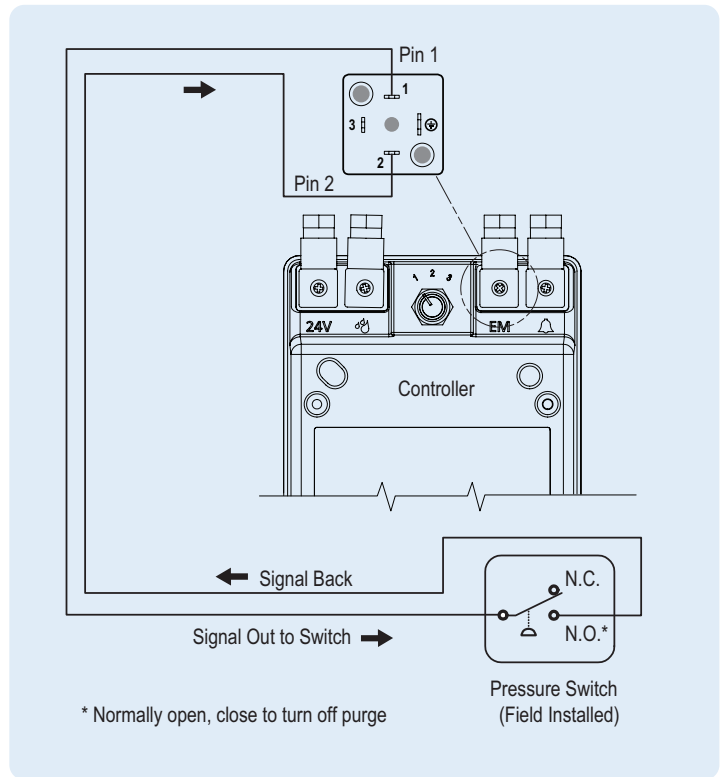
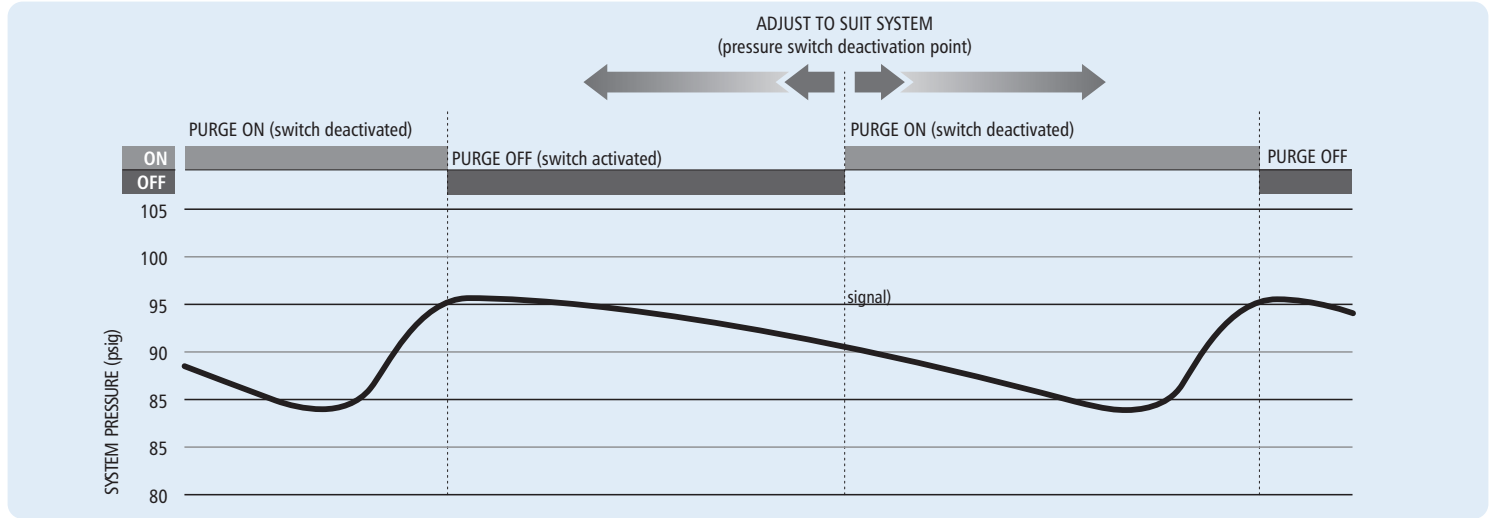



Figure 7.3: Typical installation



### Using an Electronic Pressure Switch for Purge Control

The best choice if using a pressure switch is to select an electronic programmable type pressure switch which is effectively a pressure transmitter and process controller built into one device. While significantly more costly than a standard pressure switch, an electronic programmable pressure switch can be setup to provide a much more customized operation. Typically, the dead band can be reduced or eliminated so that an immediate reaction to system pressure in system indicating air flow, can be obtained.

It is extremely important to understand that the purge may only be shut off during periods of low or no demand. This feature, if used otherwise, can result in permanent damage to the desiccant beds resulting in loss of drying capacity and possibly mechanical failure. The cartridges must not be allowed to become fully saturated at any time.

Figure 7.4 offers an overview of the Electronic Pressure Switch device mentioned as it might be connected for use in controlling a dryer's purge function. Please note that specific details differ between device manufacturers, so in all cases the manufacturer's specifications should be adhered to.

Figure 7.4 Electronic pressure switch for purge control

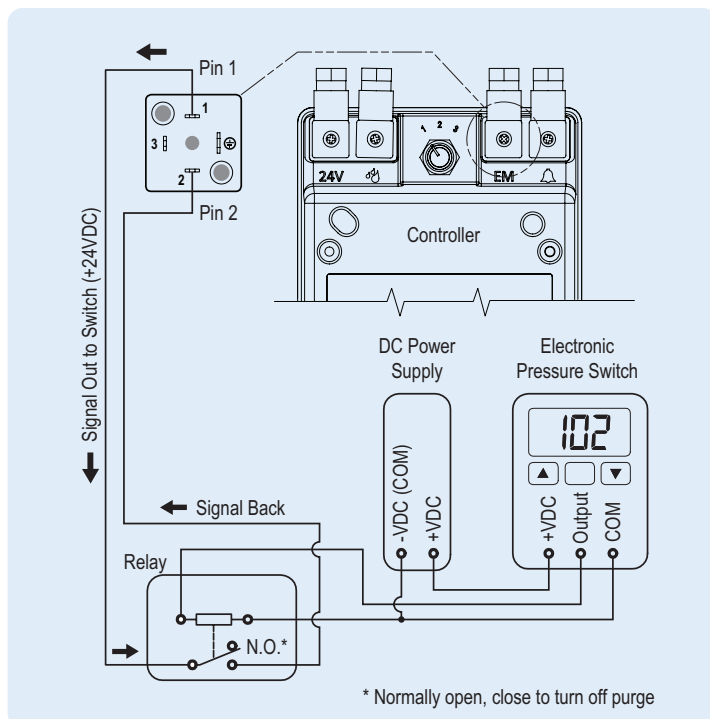

This setup is for example only. This configuration can be amended, depending on application.

Using a hygrometer and process controller for purge control

The best option for purge control if the delivered dryness (pressure Dewpoint) of the air from the dryer is critical. If the air is deemed dry enough, then the purge can be shut off until the air's moisture starts to climb. If the purge is turned off, care must be taken to ensure that the desiccant beds are not allowed to wet out too far before the purge is turned back on. Also, after turning the purge back on, the air's pressure Dewpoint may increase a bit before starting to drop again. This should be taken into consideration to ensure that the air flow remains sufficiently dry.

It is extremely important to understand that the purge may only be shut off during periods of low or no demand. This feature, if used otherwise, can result in permanent damage to the desiccant beds resulting in loss of drying capacity and possibly mechanical failure. The cartridges must not be allowed to become fully saturated at any time.

Figure 7.5 offers an overview of the device mentioned as it might be connected for use in controlling a dryer's purge function. Please note that specific details differ between device manufacturers, so in all cases the manufacturer's specifications should be adhered to.

Making connections between a switching device & dryer Energy Management contact

Cable / Wire Selection Criteria:

Selected wire should have:

At least 2 conductors. More conductors can be useful in the case of a conductor break. Conductors can be swapped without having to run new cable.

- A conductor gauge of no greater than 18 awg is recommended to fit comfortably into the DIN connector insert.
- An outside diameter of no greater than 1/4" (6mm). Larger diameters do not fit well into the cable gland of the EM DIN connectors.
- An insulation type compatible with the environment that it will be run in.

Figure 7.5: Process controller & hygrometer

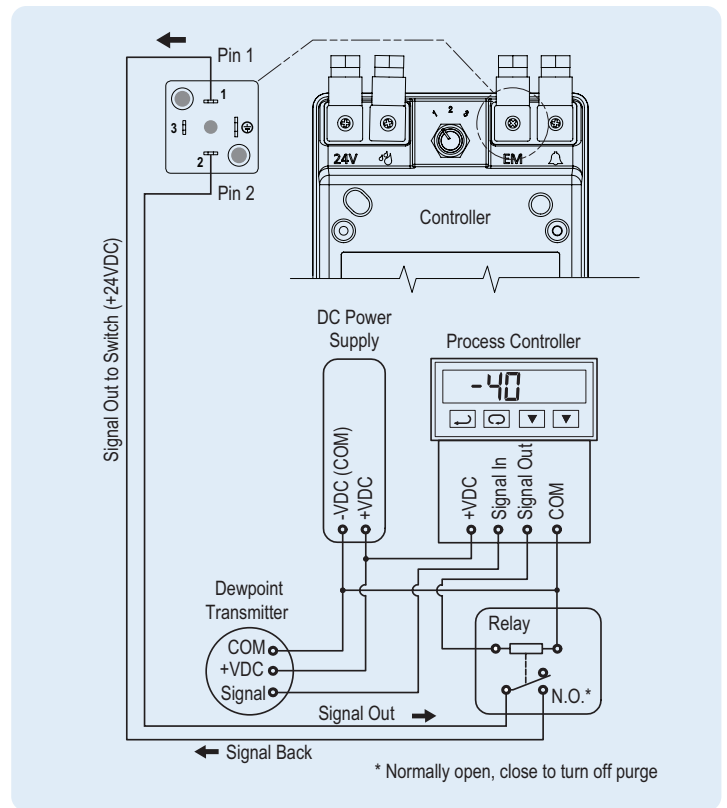

This setup is for example only. This configuration can be amended, depending on application.

### Making connections between a switching device and dryer Energy Management contact.

- Make the connection at the switch end first. This way you can check continuity at the dryer end before connecting to the dryer. Make sure that the contacts on the switch are normally open. Pin 1 of the dryer EM connection puts out a 5 VDC signal. Take care to ensure that the contacts on the switching device are 'dry' and free of any voltage which could harm the dryer controller.
- Locate the DIN connector on the back of the controller per Figure 7.7.
- Remove the screw completely from the center of the connector.
- Remove the blanking plug from the connector and discard.
- Insert a small screwdriver into the small recess at the edge of the insert, pry the insert out of the DIN connectors outer shell per Figure 7.6.
- Slip cable end through DIN connector's cable gland, washer, grommet and out through the front of the DIN connector case.
- Strip the outer insulation of the cable back approx 3/4" (20mm).
- Strip the conductor insulation back approx 1/8" (3mm).
- If possible using a meter, verify the switch function.
- Insert conductors into pins 1 & 2 of insert. Tighten retaining screws securely.
- Determine which direction the cable gland should point.
- Carefully pull the cable back through the shell until the insert snaps back into place. Take care to work the wires around the retaining screw hole as they can become fairly easily pinched.
- Plug the DIN connector back onto the dryer's EM connection.

Figure 7.7: Connecting to EM port

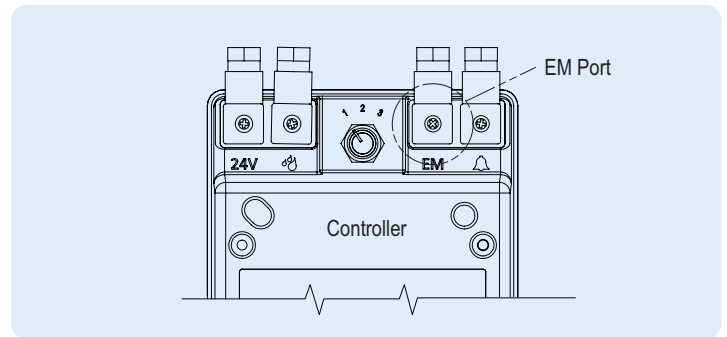
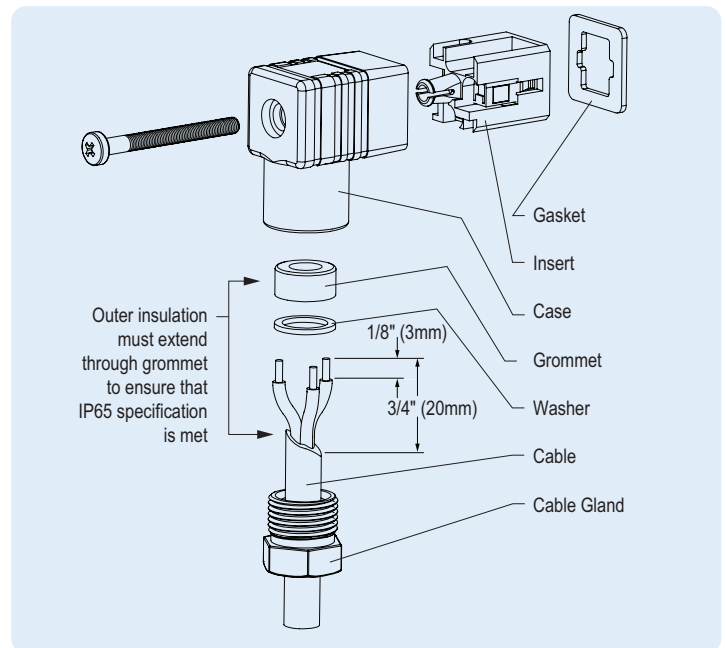
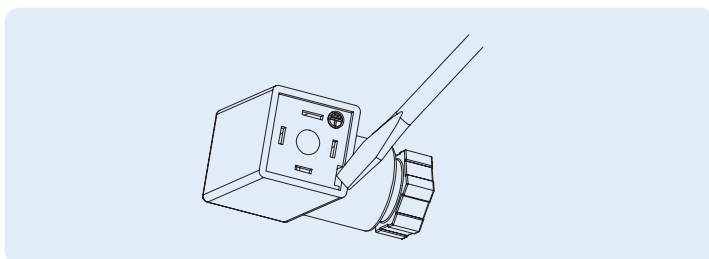

Figure 7.8: DIN connector for Internal Details



**The male ground pin is slightly wider than pins 1 & 2. Take care to ensure that the female connector is oriented correctly.**

Figure 7.6: DIN connector Insert removal



# Maintenance

## Information

All maintenance information is provided in service / maintenance leaflets. These leaflets are provided with each serviceable item / kit showing how to carry out the change-out component.

- Desiccant Cartridge service leaflet
- Purge Orifice disc service leaflet
- Exhaust Silencer service leaflet
- Main Shuttle service leaflet
- Exhaust Shuttle service leaflet

Service Intervals / Applicable Service Kits	
Pre- Filter Element	Every 1 year or 6000 hours
Exhaust silencer	Every 1 year or 6000 hours
Desiccant cartridges	Every 2 years or 12000 hours
Main shuttle	Every 4 years or 24000 hours
Exhaust shuttle	Every 4 years or 24000 hours
Solenoid valves	Every 4 years or 24000 hours
Purge orifice	Every 4 years or 24000 hours

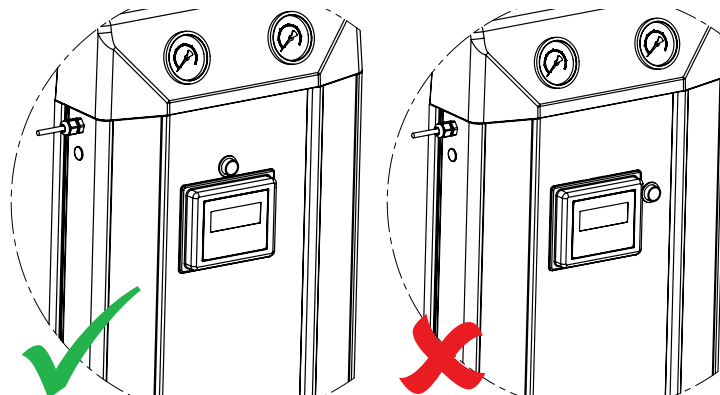
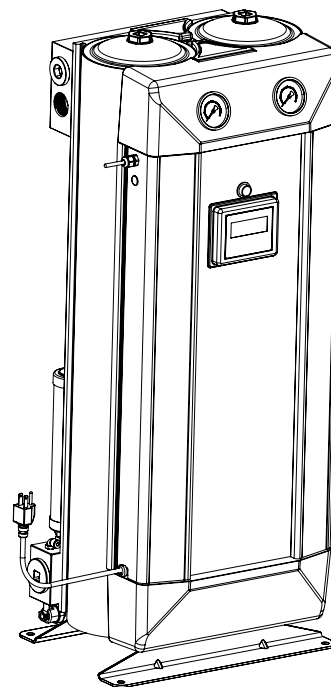

**Important information.**



**Ensure shutdown and start-up procedures are followed prior to carrying out any maintenance work on the dryer.**



**The manufacturer will not accept responsibility for physical injury, damage or delays caused by failure to observe the instructions in this manual and manuals provided with your equipment.**

# Service kits

## 6,000 hours or Annual Maintenance Kit

Dryer Model	Kit Part Number (with float drain)	Kit Part Number (with BEKOMAT®)	Description	Change-Out Period
ACC 46 to ACC 75	4048822	4022724	Pre-filter replacement element and drain service kit	6,000 Hours or 1 Year
ACC 90 to ACC 110	4048823	4022725		

## 12,000 hours or 2 years, Maintenance Kit A

Dryer Model	Kit Part Number (with float drain)	Kit Part Number (with BEKOMAT®)	Description	Change-Out Period
ACC 46	4054029	Consult factory	12,000 Hour Maintenance Kit A (Kit includes all components in the 1-year kit plus desiccant cartridges, sealing o-rings with washers and service manual)	12,000 Hours or 2 Years
ACC 56	4054030	Consult factory		12,000 Hours or 2 Years
ACC 75	4054031	Consult factory		12,000 Hours or 2 Years
ACC 90	4054032	Consult factory		12,000 Hours or 2 Years
ACC 110	4054033	Consult factory		12,000 Hours or 2 Years

## Service kits

### 12,000 hours or 2 years, High Performance Desiccant Cartridge & Silencer Service Kit - for use where -100°F (-74°C) dewpoint is required

Dryer Model	Kit Part Number	Description	Change-Out Period
DPACC 46	4054034	12,000 Hour High Performance Desiccant Cartridge and Silencer Kit (Kit includes High Performance desiccant cartridges and associated seals, and silencer service kit; reference figures 10.2, 10.3 and 10.4) supplied with cartridge removal tool	12,000 Hours or 2 Years
DPACC 56	4054035		12,000 Hours or 2 Years
DPACC 75	4054036		12,000 Hours or 2 Years
DPACC 90	4054037		12,000 Hours or 2 Years
DPACC 110	4054038		12,000 Hours or 2 Years

### 18,000 hours or 3 years, Silencer Service Kit

Dryer Model	Kit Part Number	Description	Change-Out Period
ACC 46 to ACC 90	4054049	Silencer Kit (Kit includes (2) silencers; reference figure 10.2)	18,000 Hours or 3 Years
ACC 110	4055292		

# Service kits

24,000 Hours or 4 years, Maintenance Kit B					
Dryer Model	Kit Part Number (with float drain)	Kit Part Number (with BEKOMAT®)	Description	Change-Out Period	
ACC 46	4054039	Consult factory	24,000 Maintenance Kit B (Kit includes all componenets in the 1-year and 2-year kits plus a complete valve service kit and service manual)	24,000 Hours or 4 Years	
ACC 56	4054040	Consult factory		24,000 Hours or 4 Years	
ACC 75	4054041	Consult factory		24,000 Hours or 4 Years	
ACC 90	4054042	Consult factory		24,000 Hours or 4 Years	
ACC 110	4054043	Consult factory		24,000 Hours or 4 Years	

## Service kits

24,000 Hours or 4 years, High Performance Desiccant Cartridge, Silencer, Valve & Purge Valve Service Kit For use where -100°F (-74°C) dewpoint is required				
Dryer Model	Kit Part Number	Description	Change-Out Period	
DPACC 46	4054044	24,000 Hour High Performance Service Kit (Kit includes High Performance Cartridge Set, silencer service kit, solenoid kit, shuttle service kit and purge valve kit) supplied with cartridge removal tool	24,000 Hours or 4 Years	
DPACC 56	4054045		24,000 Hours or 4 Years	
DPACC 75	4054046		24,000 Hours or 4 Years	
DPACC 90	4054047		24,000 Hours or 4 Years	
DPACC 110	4054048		24,000 Hours or 4 Years	



## Service kits

<b>Solenoid Kit</b> (Kit includes (2) solenoid control valves with attached tube fittings; reference figure 10.4)		
Dryer Model	Kit Part Number	Description
ACC 46 to ACC 110	4054051	Solenoid Valve Kit

<b>Shuttle Service Kit</b> (Kit includes (1) control shuttle, (2) exhaust shuttles and associated seals; reference figure 10.2)		
Dryer Model	Kit Part Number	Description
ACC 46 to ACC 110	4054050	Simplex Shuttle Service Kit

<b>Controller Kit</b> (Kit includes (1) controller and (2) control solenoid valves with installed tube fittings; reference figure 10.4)		
Dryer Model	Kit Part Number	Description
ACC 46 to ACC 110	4054052	Digital Display Controller Complete Kit (with 2 Valves)

<b>Purge Orifice/Valve Kits (complete)</b> Complete kit for dryers operating between 58 psig & 188.5 psig (4 barg & 13 barg) and appropriate purge orifice discs, fully assembled; reference figure 10.5		
Dryer Model	Kit Part Number	Description
ACC 46	4055293	45 SCFM - 55 SCFM Purge valve kit
ACC 56		
ACC 75	4055309	75 SCFM - 110 SCFM Purge valve kit
ACC 90		
ACC 110		

<b>Master Seal Kit</b> (Kit includes all seals (except purge orifice seals); reference figures 10.1, 10.2 and 10.3)		
Dryer Model	Kit Part Number	Description
ACC 46 to ACC 110	4054053	Simplex master seal kit

# Accessory kits

<b>Din Plug Kit</b>		(Kit includes (1), 3 pole + ground industrial standard DIN connector)
Dryer Model	Kit Part Number	Description
ACC 46 to ACC 110	Consult factory	Female DIN plug kit

<b>Power Supply Kit</b>		(Kit includes power supply and DIN connector)
Dryer Model	Kit Part Number	Description
ACC 46 to ACC 110	Consult factory	Power Supply Unit: 100-240V to 24VDC Power Supply Lead (24VDC controller only)



Although the power supply is supplied separately as an accessory and meets the required CE and UL approval, it is the responsibility of a competent person installing the equipment that all local installation regulations are adhered to.

# Component parts

45 SCFM - 110 SCFM

Fig 10.1 Top manifold assembly

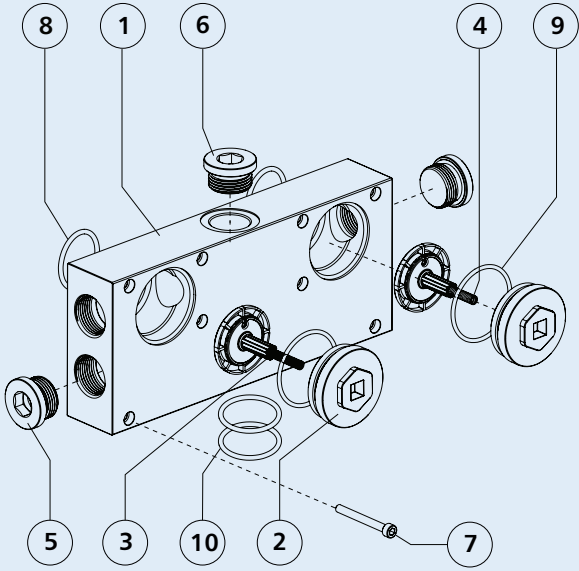

Item	Description	Qty	Included in Service / Accessory Kit	
			Master Seal	Simplex
1	Inlet / outlet manifold	1		
2	Purge valve service plug	2		
3	Purge control valve	2	See figure 10.6	
4	Valve control spring	2		
5	Inlet/outlet blanking plug	2		
6	Port plug	1		
7	Manifold fixing bolts	8		
8	Manifold connection O-ring	2		✓
9	Valve service plug O-ring	2		✓
10	Down tube O-ring	2		✓

Fig 10.2 Bottom manifold assembly

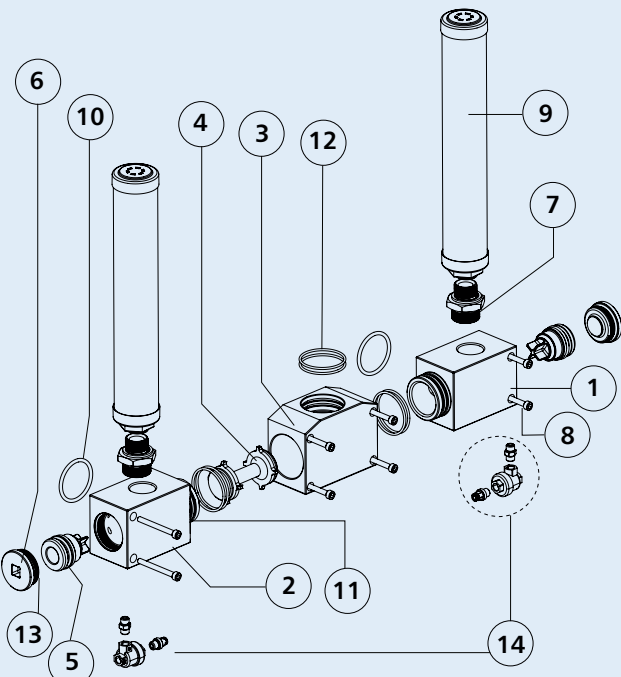

Item	Description	Qty	Included in Service / Accessory Kit			
			Valve Service (24,000 hr)	Shuttle Service (24,000 hr)	Silencer (6,000, 12,000, 18,000 and 24,000 hr)	Master Seal
1	RH exhaust manifold	1				
2	LH exhaust manifold	1				
3	Centre shuttle manifold	1				
4	Control shuttle	1	✓	✓		
5	Exhaust control valve	2	✓	✓		
6	Valve service plug	2				
7	Silencer adapter	2				
8	Manifold fixing bolt	8				
9	Silencer	2				
10	Manifold connection O-ring	2			✓	
11	Exhaust manifold O-ring	2	✓	✓		✓
12	Down tube O-ring	4	✓	✓		✓
13	Valve Service Plug O-ring	2				✓
14	Quick Exhaust Assembly	2				

45 SCFM - 110 SCFM

Fig 10.3 Tower assembly (Simplex)

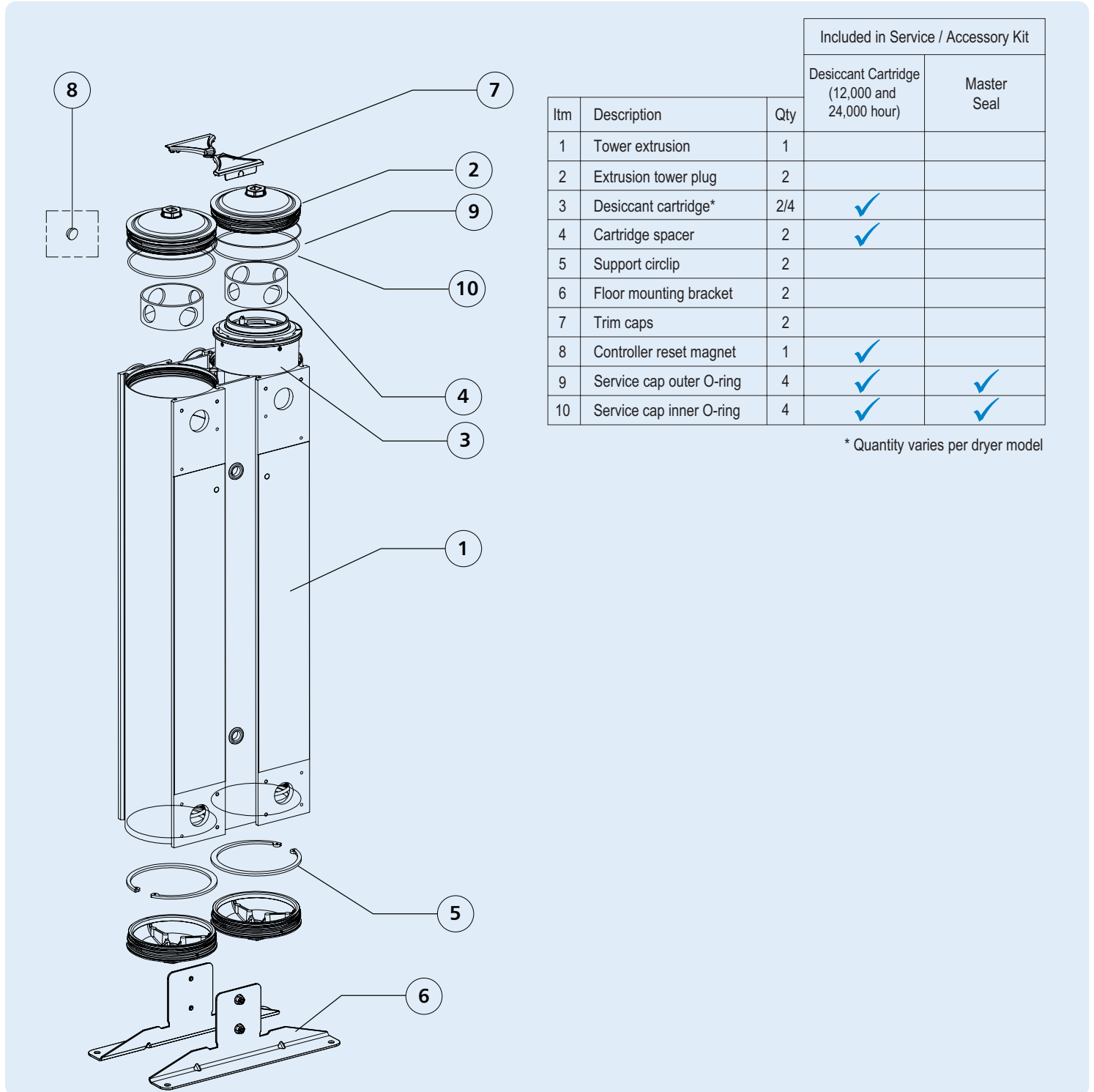

Item	Description	Qty	Included in Service / Accessory Kit	
			Desiccant Cartridge (12,000 and 24,000 hour)	Master Seal
1	Tower extrusion	1		
2	Extrusion tower plug	2		
3	Desiccant cartridge*	2/4	✓	
4	Cartridge spacer	2	✓	
5	Support circlip	2		
6	Floor mounting bracket	2		
7	Trim caps	2		
8	Controller reset magnet	1	✓	
9	Service cap outer O-ring	4	✓	✓
10	Service cap inner O-ring	4	✓	✓

\* Quantity varies per dryer model

45 SCFM - 110 SCFM

Fig 10.4 Controller Assembly

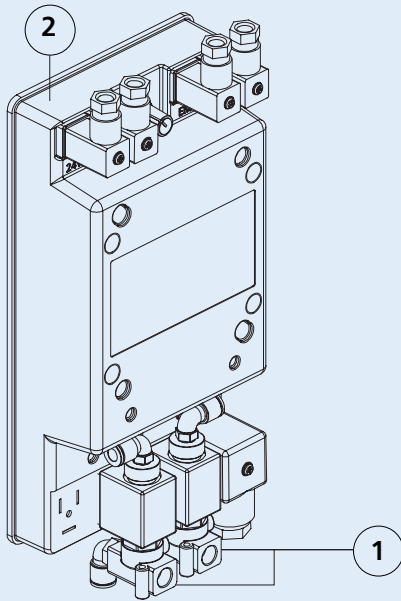

Itm	Description	Qty	Included in Service /Accessory Kit		
			Valve Service	Solenoid	Controller**
1	Solenoid control valves*	2	✓	✓	✓
2	Controller	1			✓

\* Includes installed tube fittings

NOTE: Only solenoid valve body is replaced during service.

Fig 10.5 Purge valve kits

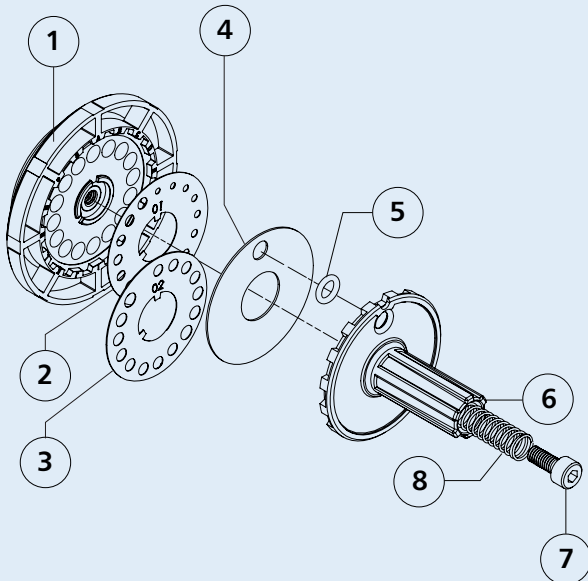

Itm	Description	Qty	Included in Service / Accessory Kit	
			ACC 46 - ACC 56	ACC 75N- ACC 110N
1	Purge valve body	2	✓	✓
2	Orifice disc (01)	2	✓	✓
3	Orifice disc (02)	2		✓
4	Sealing gasket (1 Hole)	2	✓	✓
5	Valve stem O-ring	1	✓	✓
6	Valve stem (1 Hole)	2	✓	✓
7	M4 screw	2	✓	✓
8	Valve control spring	2	✓	✓

# Troubleshooting

## General troubleshooting

Before specific identification of any fault is looked for, the following general points must be verified:

- *Has the unit been damaged externally or are any parts missing?*
- *Is power being supplied to the unit?*
- *Was start-up carried out in accordance with the instructions in this manual?*
- *Are all external valves correctly set for operation?*
- *Do the operational conditions meet those specified at time of ordering and used for product selection?*
- *Did the dryer operate normally for a period of time before the problem occurred?*



Before calling for service assistance, please obtain dryer model and serial number from dryer specification label.

Troubleshooting: General		
Problem	Possible Cause	Action
Poor dewpoint	Liquid water at dryer inlet	Check pre-filtration and drains
	Excessive flow	Check actual flow against maximum specified
	Low inlet pressure	Check against specification
	High inlet temperature	Check against specification
	Incorrect purge orifice size	Check against specification and reconfigure
	Silencer blocked or damaged	Replace silencer
	Air leaks	Tighten joints or fit new seals
	Desiccant life exceeded	Replace desiccant cartridges
	Desiccant contaminated	Check inlet filter and drains, replace cartridges
	EM is active when air is flowing through dryer	Check EM wiring
Power to dryer off while air is flowing through dryer	Ensure that power is on whenever air is flowing through dryer	
Incorrect dryer operation, won't switch towers	Jammed shuttle valves	Clean or replace shuttles
	Faulted electrical components	See electrical operation troubleshooting section
Incorrect dryer operation, won't depressurize towers	Jammed purge exhaust shuttle	Clean or replace exhaust shuttles and solenoid valves
	Blocked and/or damaged silencer	Replace silencer
Excessive or loud purge, or purge on only one tower	Jammed main control shuttle valve	Clean or replace shuttles
	Jammed purge exhaust shuttle	Clean or replace exhaust shuttles
	Faulty solenoid valve	Clean or replace solenoid valve
	Not utilizing Energy Management feature	Refer to Energy Management instructions (Section 7)
	Blocked and/or damaged silencer	Replace silencer and check desiccant cartridges
	Damaged purge valve(s)	Replace purge valve bodies
	Incorrect purge orifice size	Double check and select correct size

Troubleshooting: Electrical		
Problem	Possible Cause	Action
No dryer function	No power supply	Check supply
	Power connected to wrong controller input	Check connections with specifications listed in Section 5
	Faulty controller	Replace controller
Dryer does not activate external alarm when display panel indicates alarm condition	Shorted or incorrect device wiring	Correct external wiring
	External power not supplied	Add external power source per specifications given in Section 5
	Faulty external indication device	Repair or replace device
	Faulty controller	Replace controller

Troubleshooting: Energy Management		
Problem	Possible Cause	Action
Dryer does not enter Energy Management when switching device is activated <i>and/or</i> Dryer does not enter Energy Management when EM contacts are opened.	Shorted or incorrect device wiring	Remove external wiring from the dryer's EM contacts: <ul style="list-style-type: none"> <li>Place jumper between pins 1 and 2 of EM male connector. Dryer should enter EM mode.</li> <li>If dryer enters EM mode, correct external wiring problem</li> <li>If dryer does not enter EM mode, replace controller</li> </ul>
	Faulty switching device	Consult device manufacturer
	Faulty controller output	Replace controller

## Section 11: Troubleshooting

Function	Indication	Remark								
Full Digital Display Controller message layout	<table border="1"> <tr><td>Line message 1</td><td></td></tr> <tr><td>Line message 2</td><td></td></tr> <tr><td>Line message 3</td><td></td></tr> <tr><td>Line message 4</td><td></td></tr> </table>	Line message 1		Line message 2		Line message 3		Line message 4		
Line message 1										
Line message 2										
Line message 3										
Line message 4										
Dryer functioning in standard running mode	<table border="1"> <tr><td>Line message 1</td><td>STANDARD RUNNING MODE</td></tr> <tr><td>Line message 2</td><td>-</td></tr> <tr><td>Line message 3</td><td>HOURS RUN XXXXX</td></tr> <tr><td>Line message 4</td><td>SERVICE HISTORY # XX</td></tr> </table>	Line message 1	STANDARD RUNNING MODE	Line message 2	-	Line message 3	HOURS RUN XXXXX	Line message 4	SERVICE HISTORY # XX	
Line message 1	STANDARD RUNNING MODE									
Line message 2	-									
Line message 3	HOURS RUN XXXXX									
Line message 4	SERVICE HISTORY # XX									
Dryer functioning in standard running mode (service due)	<table border="1"> <tr><td>Line message 1</td><td>STANDARD RUNNING MODE</td></tr> <tr><td>Line message 2</td><td>-</td></tr> <tr><td>Line message 3</td><td>SERVICE DUE (XXX HOURS)</td></tr> <tr><td>Line message 4</td><td>SERVICE HISTORY # XX</td></tr> </table>	Line message 1	STANDARD RUNNING MODE	Line message 2	-	Line message 3	SERVICE DUE (XXX HOURS)	Line message 4	SERVICE HISTORY # XX	Service due (500 hour countdown until 12000 hours continuous operation)
Line message 1	STANDARD RUNNING MODE									
Line message 2	-									
Line message 3	SERVICE DUE (XXX HOURS)									
Line message 4	SERVICE HISTORY # XX									
Dryer functioning in standard running mode (service overdue)	<table border="1"> <tr><td>Line message 1</td><td>STANDARD RUNNING MODE</td></tr> <tr><td>Line message 2</td><td>-</td></tr> <tr><td>Line message 3</td><td>SERVICE OVERDUE</td></tr> <tr><td>Line message 4</td><td>SERVICE HISTORY # XX</td></tr> </table>	Line message 1	STANDARD RUNNING MODE	Line message 2	-	Line message 3	SERVICE OVERDUE	Line message 4	SERVICE HISTORY # XX	Service overdue (12000 hours continuous operation)
Line message 1	STANDARD RUNNING MODE									
Line message 2	-									
Line message 3	SERVICE OVERDUE									
Line message 4	SERVICE HISTORY # XX									
Energy management mode active	<table border="1"> <tr><td>Line message 1</td><td>ENERGY MANAGEMENT MODE</td></tr> <tr><td>Line message 2</td><td>-</td></tr> <tr><td>Line message 3</td><td>HOURS RUN XXXXX</td></tr> <tr><td>Line message 4</td><td>SERVICE HISTORY # XX</td></tr> </table>	Line message 1	ENERGY MANAGEMENT MODE	Line message 2	-	Line message 3	HOURS RUN XXXXX	Line message 4	SERVICE HISTORY # XX	
Line message 1	ENERGY MANAGEMENT MODE									
Line message 2	-									
Line message 3	HOURS RUN XXXXX									
Line message 4	SERVICE HISTORY # XX									
Energy management mode active (service due)	<table border="1"> <tr><td>Line message 1</td><td>ENERGY MANAGEMENT MODE</td></tr> <tr><td>Line message 2</td><td>-</td></tr> <tr><td>Line message 3</td><td>SERVICE DUE (XXX HOURS)</td></tr> <tr><td>Line message 4</td><td>SERVICE HISTORY # XX</td></tr> </table>	Line message 1	ENERGY MANAGEMENT MODE	Line message 2	-	Line message 3	SERVICE DUE (XXX HOURS)	Line message 4	SERVICE HISTORY # XX	Service due (500 hour countdown until 12000 hours continuous operation)
Line message 1	ENERGY MANAGEMENT MODE									
Line message 2	-									
Line message 3	SERVICE DUE (XXX HOURS)									
Line message 4	SERVICE HISTORY # XX									
Energy management mode active (service overdue)	<table border="1"> <tr><td>Line message 1</td><td>ENERGY MANAGEMENT MODE</td></tr> <tr><td>Line message 2</td><td>-</td></tr> <tr><td>Line message 3</td><td>SERVICE OVERDUE</td></tr> <tr><td>Line message 4</td><td>SERVICE HISTORY # XX</td></tr> </table>	Line message 1	ENERGY MANAGEMENT MODE	Line message 2	-	Line message 3	SERVICE OVERDUE	Line message 4	SERVICE HISTORY # XX	Service overdue (12000 hours continuous operation)
Line message 1	ENERGY MANAGEMENT MODE									
Line message 2	-									
Line message 3	SERVICE OVERDUE									
Line message 4	SERVICE HISTORY # XX									



# Warranties and liabilities

Claims for warranty and liability concerning personal injury or material damage are excluded if they resulted due to one or more of the following factors:

- *Inappropriate use.*
- *Inappropriate application of the dryer.*
- *Technically incorrect installation, start-up operation or maintenance of the dryer.*
- *Operation of a known damaged dryer.*
- *Failure to observe the information given in this manual concerning all life phases of the dryer.*
- *Undertaking constructional or operational modifications to the dryer without prior agreement with the manufacturer.*
- *Inadequate monitoring and replacement of components of the dryer that are subject to wear.*
- *Improper completion of repairs.*
- *Use of non-original or non-approved parts for service or maintenance.*



The warranty of this product could become void if the correct filtration is not installed upstream of the dryer. It is recommended that the inlet filtration upstream of the dryer consists of a water separator, 1.0  $\mu$  then 0.01  $\mu$ . However, it is essential that a water separator followed by a 0.01  $\mu$  is used.

## Important Note

# Industrial Compressed Air Desiccant Dryers

The manufacturer desiccant dryer range is designed for, warrantied and intended for use in fixed industrial compressed air applications only. Use on non-fixed installations such as :

- *marine (e.g. offshore, shipboard)*
- *transportable (e.g. portable air treatment units)*
- *non-fixed (e.g. rolling stock, railway etc)*

are not strictly prohibited, however use in such applications is not recommended nor endorsed as additional design features, function testing, certification (both mechanical and electrical) and validation may be required to satisfy relevant end user application specific specifications and/or mandatory and non-mandatory local, national or international standards and legislation.



Such additional undertakings are the responsibility of the package or system builder, installer or end user.

---

# Notes



---

# Notes





BEKO TECHNOLOGIES CORP. 900 Great SW Parkway, Atlanta, Georgia 30336, USA  
+1 (800) 235-6797 Phone +1 (404) 629-6666 Fax [beko@bekousa.com](mailto:beko@bekousa.com) [www.bekousa.com](http://www.bekousa.com)

---

BEKO reserves the right to make changes and improvements to the product and/or this manual without prior notice.